

NATIONAL ENGINEERING HANDBOOK

SECTION 16

DRAINAGE OF AGRICULTURAL LAND

CHAPTER 7. DRAINAGE PUMPING

	<u>Contents</u>	<u>Page</u>
Scope		7-1
Nomenclature and Definitions		7-2
Need for Pumping		7-5
Location of the Pumping Plant		7-5
Incorporating the Pumping Plant in the Drainage System		7-6
Static Lift		7-7
Optimum stage		7-7
Maximum static lift		7-8
Minimum static lift		7-8
Average lift		7-8
Pumping Plant Capacity		7-9
Determining factors		7-9
Small surface areas		7-10
Large surface areas		7-12
Special areas		7-12
Upper Mississippi Valley		7-12
Florida		7-13
Subsurface drainage		7-13
Pumping Plant Design		7-13
Selection of pumps		7-13
Types of pumps		7-14
Axial flow or propeller pumps		7-14
Mixed flow pumps		7-17
Radial flow pumps		7-17
Number of pumps		7-17
Pumping requirements		7-18
Performance of pumps		7-18
Total dynamic head		7-18
Suction pipe head losses		7-21
Net positive suction head (NPSH)		7-21
Discharge pipe losses		7-22
Specific speed		7-25
Pump size		7-31
Power and drives		7-33
Electric motors		7-33
Internal combustion engines		7-35
Power drives		7-35

ContentsPage

Power requirements	7-35
Operating controls	7-36
Safety controls	7-39
Recorders and signaling devices	7-40
Sump dimensions	7-40
Sump capacity	7-44
Stop logs	7-45
Trash racks	7-45
Discharge pipes	7-46
Housing	7-47
Field Tests of Drainage Pumping Plants	7-48
Procedure for field tests	7-48
Surveys and gages	7-48
Total head on pump	7-48
Discharge measurements	7-49
Discharge measurements with Tulane pitot tubes	7-49
Pump efficiency	7-51
Operation and Maintenance	7-53
References	7-54

Figures

Figure 7-1	Pumping plant layout	7-3
Figure 7-2*	Propeller or axial flow pump	7-15
Figure 7-3*	Classes of centrifugal pumps	7-16
Figure 7-4	Pump type selection chart	7-19
Figure 7-5	Pump characteristic performance curves	7-20
Figure 7-6	Head losses in riveted steel pipe	7-24
Figure 7-7	Head losses for light flap gates	7-26
Figure 7-8*	Relationship of impeller design and specific speeds	7-27
Figure 7-9*	Limits of specific speed, single suction, radial and mixed flow pumps	7-28
Figure 7-10*	Limits of specific speed, double suction, radial flow pumps	7-29
Figure 7-11*	Limits of specific speed, single suction, mixed and axial flow pumps	7-30
Figure 7-12	Motor selection chart	7-34
Figure 7-13	Types of automatic control	7-38
Figure 7-14*	Sump dimensions versus flow	7-41
Figure 7-15*	Sump dimensions and pump arrangement	7-42
Figure 7-16*	Sump dimensions and pump arrangement	7-43
Figure 7-17	Suction and discharge gages for pumping plant field tests	7-50
Figure 7-18	Tulane pitot tube and template for measuring water velocity in pipes	7-52

*See Note page 4

Tables

Table 7-1	Properties of water at various altitudes	7-23
Table 7-2	Properties of water at various temperatures	7-23
Table 7-3	Pump classification according to speed and pressure magnitude	7-31
Table 7-4	Pump size according to capacity and discharge velocity	7-32

ContentsPage

APPENDIX A

Determining Pumping Plant Capacity Based on Hydrologic and Economic Factors	7A-1
Example	7A-1
Rainfall determination	7A-1
Runoff determination	7A-1
Runoff, pumping rate, storage relationships	7A-5
Stage-storage relationships	7A-8
Stage, damage area, benefit area relationships	7A-8
Pumping rate, storage, and damage area relationships	7A-10
Value of damages and benefits	7A-10
Operating costs	7A-20
Pumping rate at optimum cost-benefit ratio	7A-20

Figures

Figure 7A-1	Pumping plant location	7A-2
Figure 7A-2	Rainfall duration-frequency	7A-4
Figure 7A-3	Mass runoff, frequency, duration, and pumping rate relationships	7A-6
Figure 7A-4	Maximum required storage for various chances of occurrence and pumping rates	7A-7
Figure 7A-5	Average annual storage at various pumping rates	7A-9
Figure 7A-6	Relationships of stage, storage, and affected areas	7A-11
Figure 7A-7	Acre-days impaired drainage at 1/2 inch pumping rate for various frequencies	7A-14
Figure 7A-8	Impaired drainage damages with no pumping	7A-16
Figure 7A-9	Value of damage by impaired drainage at 1/2 inch per day pumping rate	7A-17
Figure 7A-10	Cost-benefit relationship at various pumping rates	7A-19

Tables

Table 7A-1	Rainfall - runoff duration - frequency	7A-3
Table 7A-2	Hydrograph base time length	7A-5
Table 7A-3	Required maximum storage, inches	7A-5
Table 7A-4	Average annual storage for various pumping rates	7A-8
Table 7A-5	Stage, area, storage relationships	7A-8
Table 7A-6	Relationships - stage to impaired drainage area	7A-10
Table 7A-7	Relationships - stage, storage, pumping rate, and affected acres	7A-10
Table 7A-8	Relationships - pumping rate to benefits	7A-12
Table 7A-9	Relationships - impaired drainage and storage for various frequencies and pumping rates	7A-13
Table 7A-10	Damages for various pumping rates and frequencies of occurrence	7A-15
Table 7A-11	Average annual damages and benefits for various pumping rates	7A-18
Table 7A-12	Cost-benefits at various pumping rates	7A-20
Table 7A-13	Relationships - cost-benefit at various pumping rates	7A-21

ContentsPage

APPENDIX B

Design of Farm Drainage Pumping Plant	7B-1
Example	7B-1
Pump plant location	7B-1
Pump plant capacity	7B-1
Pump type and size	7B-1
Engine size	7B-4
Required power	7B-7
Sump dimensions	7B-8

Figures

Figure 7B-1	Pump drainage site layout	7B-2
Figure 7B-2	Cross section of pumping plant layout	7B-3
Figure 7B-3	Layout of principal dimensions - vertical axial flow pumps	7B-5
Figure 7B-4	Table of principal dimensions - vertical axial flow pumps	7B-6

Note: Figures 7-2, 7-3, 7-8, 7-9, 7-10, 7-11, 7-14, 7-15 and 7-16 reprinted from HYDRAULIC INSTITUTE STANDARDS, 12th Edition. Copyright 1969 by the Hydraulic Institute, 122 East 42nd Street, New York, New York 10017.

NATIONAL ENGINEERING HANDBOOK

SECTION 16

DRAINAGE OF AGRICULTURAL LAND

CHAPTER 7. DRAINAGE PUMPING

Scope

Pumps may be used for disposal of water from drainage systems when discharge by gravity flow cannot be obtained because of inadequate outlets or because of backwater from storm or tidal flooding.

The complexity and requirements for planning, designing, and constructing pumping facilities vary substantially from site to site. A dependable and economical pumping plant requires detailed investigation and survey of site conditions for planning and design. Planning requires consideration of the entire drainage system served so that diversions, storage areas, channels and outlets are used to best advantage in determining capacity, size, and operation of the pumps. Design requires consideration of a combination of pumping plant components in regard to the type, size, and capacity of the pumps; the kind of power to be used; the shape, size and depth of the sump; and between one component and another, as between pumps and sump.

The essential items in both planning and design of pumping plants will include a determination of:

1. The location of the pumping plant for an effective outlet to the entire drainage system, with consideration of an adequate foundation for the plant structure, access for the operation and servicing of the facility, and economy of installation.
2. The required water removal rate, with due consideration of crop requirements, protection of associated realty improvements (as buildings, access roads, etc.), and the effects of watershed characteristics (as topography, size, surface storage, and surface and subsoil conditions).
3. Auxiliary drainage facilities (as diversions, dikes, reservoirs, sumps, and gates) for protecting the facility and minimizing the pumping requirements.
4. The kind, capacity, size and number of pumps (but excluding their design which is a manufacturer's responsibility).
5. The type of power and prime mover adaptable to the site conditions, and the power requirements, availability, and cost.
6. The arrangement and size of forebay, sump, and discharge bay for the efficient movement of water through the pumping facility.
7. Auxiliary equipment including the operating controls.
8. Housing and protection of the pumps and prime movers.

Other items also important in planning are:

1. Arrangements for plant construction.
2. Installation and testing of equipment.
3. Plant operation, including the facilities and procedures for operation, maintenance, repair, and protection.

Nomenclature and Definitions

The following is a selected list of terms and parts of a drainage pumping plant and their definitions. (See figure 7-1.) Reference should also be made to Hydraulic Institute Standards - 12th Edition (1).

Drainage Pumping Plant	- A pumping facility, including one or more pumps, power units, and appurtenances for lifting collected drainage water to a gravity outlet.
Forebay	- Supply channel and open reservoir immediately adjoining the pumping plant for the collection and temporary storage of drainage water.
Trash Rack	- Bar grate between the forebay and sump for excluding large floating objects and debris that might plug, damage, or otherwise interfere with operation of the pumps.
Sump	- Pit, tank, or portion of reservoir within the pumping plant (the suction bay) from which collected water is withdrawn by the pumps.
Radial Flow Pump	- A centrifugal type pump in which the pressure for moving water is developed principally by action of centrifugal force. Water entering at the impeller hub flows radially to the impeller periphery.
Mixed Flow Pump	- A centrifugal type pump which develops pressure by both centrifugal force and the lifting action of the impeller on the water.
Axial Flow (Propeller) Pump	- A centrifugal type pump in which the pressure is developed primarily by the lifting action of the impeller (propeller blades) on the water.
Single-stage Pump	- Pump having a single impeller.
Multistage Pump	- Pump having more than one impeller mounted on a single shaft.
Pump Submergence	- Vertical distance between inlet of the pump and the water surface in the sump.
Bottom Clearance	- Vertical distance between inlet of pump and bottom of sump.

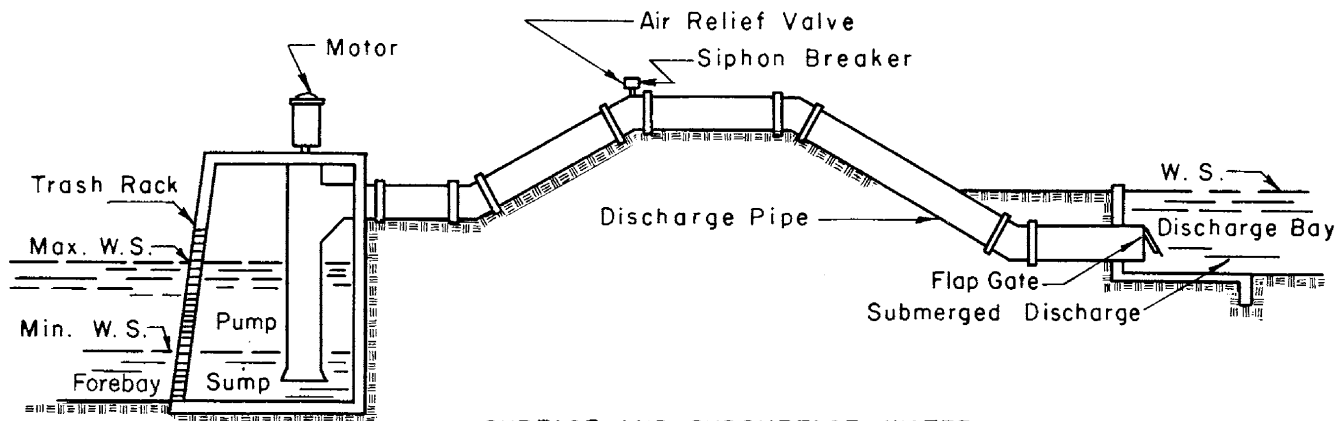

SURFACE AND SUBSURFACE WATER

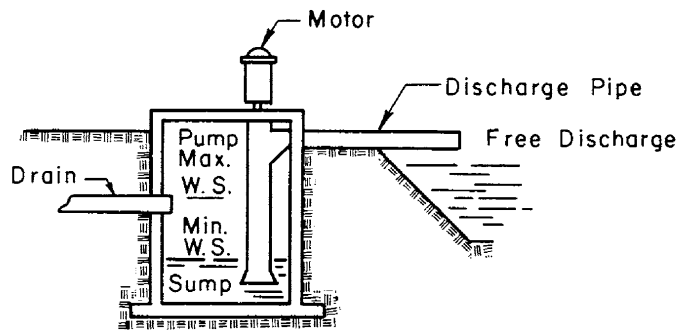

SUBSURFACE WATER ONLY

Figure 7-1, Pumping plant layout

- Side Clearance - Horizontal distance between inlet of pump and nearest part of sump wall.
- Suction Bowl - Specially shaped section of pump which diverts water to the impeller.
- Suction Bell (or Flange) - Flared section at inlet end of pump either as a part of, or directly attached to, the suction bowl or attached to a suction pipe leading to the suction bowl.
- Foot Valve - Check valve installed at inlet end of suction pipe to retain water for pumps requiring priming.
- Suction Umbrella - A formed brim sometimes attached to the suction bowl to reduce disturbance at the inlet and reduce required submergence.
- Suction Pipe - Pipe leading from water supply to the suction bowl of the pump.
- Discharge Pipe - Pipe leading from discharge opening in pump to point of discharge.
- Flap Gate - Free swinging gate which prevents backflow of water into a submerged discharge pipe when the pump is not operating.
- Discharge Bay - Structure or pool into which pump discharge pipe empties.
- Submerged Discharge - Pump discharge through a submerged pipe.
- Free Discharge - Pump discharge through an unsubmerged pipe (pipe above water surface in drainage outlet).
- Discharge Siphon - Section of discharge pipe which may operate as siphon (at less than atmospheric pressure).
- Air Relief Valve - Device for releasing air from high point in discharge pipe to utilize siphon action.
- Siphon Breaker - Device to admit air at high point in discharge pipe for stopping siphon action.
- Prime Mover - Power unit to drive the pump, as an electric motor or an internal combustion engine.
- Direct Drive - Power transmission by direct connection between shafts of prime mover and pump without use of belts, gears, or chains.
- Belt Drive - Power transmission from prime mover to pump by belts and pulleys.

Right-angle Gear Drive	Right angle beveled gears for transmission of power from horizontal drive shaft to a vertical pump shaft.
Automatic Control	System whereby starts and stops of pumping unit are regulated automatically as by a float switch, electrode switch, or bubbler unit.
Semiautomatic Control	System whereby pumping unit is started manually but stops automatically at a predetermined water level or set time interval.
Manual Control	System whereby pumping unit is started and stopped manually.
Float Control	Use of float to activate switch for starting and stopping pumping unit at predetermined water levels.
Electrode Control	Use of a pair of electrodes to activate switches for starting and stopping pumping unit at predetermined water levels.

Need for Pumping

Sites that require pump drainage usually occupy flat lowlands adjoining oceans, bays, tidal estuaries, and lakes; bottom land of large rivers; and extensive glaciated areas where the outlets are inadequate or not available. Frequently, pumping is more practical than improvement of an existing watercourse to a gravity outlet because of difficulty in obtaining easements or funds to cover cost of construction or subsequent maintenance of an improved channel.

Usually, pumping is required only for short periods of time, such as during occurrence of a seasonal high water table, a seasonally high stage of river or lake, or at times of floodflow or backwater from storm runoff of irregular occurrence.

In some situations, need for pumping may develop gradually as in river bottoms where successive areas of land along reaches of channel are converted from hay or pasture to high valued crops and urban or industrial use and subsequently enclosed by dikes for protection from flooding. Pumping may become desirable or necessary as resulting reductions in river overflow areas cause increased frequency and duration of floodflows and corresponding increased periods of blockage and impeded drainage discharge.

Need for pumping inevitably develops in drained organic soils because of land subsidence. Pumping may be the most practical way of controlling the subsidence rate through regulation of the water table level. Pumping may also be used in irrigated areas to lower and control water table levels and provide for leaching of saline and alkali soils.

Location of the Pumping Plant

A wet area may be served by one or more pumping plants. Large areas with widely separated outlets may justify more than one plant. However, lower construction and maintenance costs, but not necessarily the best dependability,

usually are obtained when the drainage system is served by a single pumping plant.

Pumping plant locations are determined chiefly by topography and ground water conditions to which the drainage system layout must be tailored. Normally the site will be at the lowest elevation of the area served and at or as close as possible to the best outlet. However, other factors to be considered in arriving at the most advantageous site are:

1. Availability of forebay storage.
2. Required location of dikes.
3. Accessibility of powerlines and fuel supply roads and their adequacy for serving the plant. Cost of improvements to roads and connecting facilities for power supply and their maintenance.
4. Adequacy for structural foundations.
5. Ground water levels and their fluctuations.
6. Protection from vandalism.

Sites adjoining ditches or watercourses near an outlet often have unstable foundations. Better locations, requiring lower construction costs, may be found on higher, more stable ground. In such cases access channels can be constructed at the more desirable site to deliver the water to the pumps and from the pumps back to the stream.

Incorporating the Pumping Plant in the Drainage System

In order to minimize the amount of water to be pumped, the runoff from all areas that can be drained by gravity should be diverted from the area served by the pumps. Where direct diversion around the pumped area is not feasible, the surface runoff occurring at the low outlet stages should be discharged by gravity through gates in the protecting dike bordering the pumped area as long as the outlet stages will permit. In some cases it may be necessary to carry upland runoff directly to the outlet between dikes constructed through the pumped area.

The drainage system served by the pumping plant should be designed to meet drainage needs with as complete and uniform coverage of the area as practical. Mains and laterals should be established, as for gravity systems, through the natural depressions leading to the outlet. When practical, lower reaches of the main ditch should utilize available sloughs and ponds so as to increase forebay storage. Impoundment in such areas permit a reduction in the size of the pumping unit and may also provide more constant operating conditions because of less fluctuation in the water stage. Large storage capacity in such forebay areas and in the suction bay or sump of the pumping plant itself has other advantages such as reducing the need for night operation in the case of manually controlled pumps, or conversely, permitting an increase in night operation for electrically operated pumps when current can be obtained more cheaply at off-peak load rates, and in reducing seepage because of smaller head differentials.

The pattern of the drainage system served by the pumping plant should be planned so as to obtain a good hydraulic grade line and nonerosive velocities

between the sump and the most remote parts of the system during pump operation after drawdown is established. A split system of mains, leading to the pumping plant from different directions and having about equal lengths and collection areas, provides better water gradients to the sump than does a long single main. The mains should have ample depth and cross section area so that flow capacity can be maintained as uniform as possible between high and low water stages at the sump. The channel capacity must be adequate for pump requirements and flow must be within velocities sustaining channel stability when elevation of the hydraulic grade line at the sump is at low water (pump-stop level) stage.

Static Lift

Static lift is the height to which pumps must lift water under given conditions. It is the difference in elevation between water stages in the sump and the discharge bay or outlet when the discharge is submerged. When the discharge is not submerged, differences between water stages in the sump and the centerline of water in the discharge pipe at the high point of discharge determine the static lift.

Operating levels at the sump are determined by elevation of land to be drained or protected from overflow; by hydraulic grade and operating levels of water in the mains and laterals of the ditch system leading to the sump; and by the elevations of outlets to subsurface drains into the ditch system. Thus static lifts should be determined after the drainage system to be served by the pumping plant has been designed.

Data relating to forebay, sump and discharge bay should be studied in order to determine the maximum, minimum, and average static lifts for the pumps. These data are needed by pump manufacturers in order for them to select and supply equipment that will operate efficiently through the controlling ranges of lifts and also provide adequate capacity at maximum lift.

Optimum stage

Optimum stage is the sump elevation at which it is desired to hold the water level.

When pumping for subsurface drainage, optimum stage should be at the level that will give drainage to the lowest wet areas. Optimum stage may vary with the seasons of the year and with weather conditions. In humid regions this will be 4 or more feet below the land surface of most of the area served. In irrigated areas of semiarid and arid regions it will be in the range of 6 to 9 feet. In areas of organic soil, shallower depths to water table should be maintained in accord with recommendations in Chapter 8, Drainage of Organic Soils, and in local drainage guides.

When surface drainage is the primary consideration, optimum stage should be at the forebay elevation of the design hydraulic grade line of the drainage system served by the pumping plant. Although the actual hydraulic grade will fluctuate between start and stop elevations of the pump over the course of the pumping cycle, the design hydraulic grade line defines both the upstream areas to be protected and the amount of forebay storage available at design flow.

If the amount of storage for the planned protection is significant, pumps should be operated in such a manner as will keep storage available for whenever it may be needed. The stop level of the pump, or at least one of the

pumps in a multiple pump installation, should be at the lowest level of the planned storage basin for which a satisfactory pumping operation can be carried out. In setting such level, it should be kept in mind that pumping water too low may not only increase static lift but also result in suction of air into the pump and decreased pumping efficiency.

The pump-start level on automatically operated pumps should be set slightly lower than the design hydraulic grade line. In a manually controlled installation, the operator may need to anticipate weather conditions in determining pump start if an independent float-controlled or similar warning system is not used.

When both surface and subsurface drainage are to be handled by the same plant, a distinction between the two needs to be made. Generally, more than one pump would be required in draining large areas. In such case, a low volume pump would be used for subsurface flow and larger capacity pumps for surface flow, with optimum stage of each set accordingly. If a single pump is used to handle both surface and subsurface drainage, as is often the case in draining small areas, optimum stage for surface drainage would govern the pump selection and requirements for subsurface drainage would determine the pump-stop level.

Maximum static lift

Maximum static lift is the difference between the pump-stop stage in the sump and the maximum stage in the discharge bay or outlet when the discharge is submerged. If the discharge is not submerged, the high point in the center-line of the discharge pipe controls the maximum elevation of the lift. Maximum static lift should be determined with care to assure that adequate plant capacity is available during flood stages. Maximum stages in the discharge bay may be determined by establishing gaging stations or from records obtained from the Weather Bureau, Corps of Engineers, U.S. Geological Survey, municipalities, local newspaper files, and by inquiry of local residents.

Studies of operating conditions during flood periods have emphasized the importance of designing pumping plants for full capacity at maximum lift. Pumps discharging into large streams or rivers may need to operate for several days or longer at full capacity before maximum flood stages occur in the outlet and then continue operation until flood crests have passed.

Minimum static lift

Minimum static lift for pumps having a submerged discharge pipe can be estimated as the difference between the minimum stage of the discharge bay and the optimum stage of the sump. Where the minimum elevation of the discharge bay is above the controlling stage of a river or lake and also some distance removed, advantages of enlarging and deepening the connecting channel or removing obstructions should be considered.

Average lift

Pumping efficiency becomes an important factor in operating costs when plants are operated more or less continuously over an extended period of time (as much as 60 to 90 days for some facilities). In such cases, the average lift provides a better basis for establishing the most efficient pumping range. Where records of existing installations are available and the area and conditions are comparable, average lifts can be established from records of average

monthly lifts of operating plants weighted according to the amount of water pumped in respective months.

Pumping Plant Capacity

Determining factors

The required capacity of pumping plants may be determined from (a) drainage coefficients applied to the area served, (b) empirical formulas, (c) a study of existing installations, or (d) direct analysis using hydrologic procedures.

The capacity selected for the pumping plant should give consideration to such factors as size of the area served; the amount, rate and timing of rainfall and runoff; ground water conditions; and seepage rates.

For small areas of land ranging up to a square mile, complete and uniform benefits are usually necessary and obtainable. Thus the amount of water to be pumped should be about the same as would be required for a gravity drainage system with free outlet. Pumping plant capacity is usually determined on a daily rate basis so that for surface drainage systems the required capacity can be determined as the runoff from a 24-hour rainfall of a selected frequency of occurrence, plus base flow, less allowances for available surface and ground water storage. Rainfall periods exceeding 24 hours may need to be considered in evaluating available surface and ground water storage. Pumping plant capacity for removal of ground water only, as may apply in irrigated areas of the arid regions or areas of organic soils in humid regions, can be determined from the required capacity of subsurface drainage systems as covered in Chapter 4, Subsurface Drainage. However, experience in humid regions has shown the necessity of increasing this rate approximately 20 percent.

A number of interrelated factors need to be considered in arriving at an approximate pumping plant capacity for large land areas. These areas will contain small tracts where protection by pumping is neither necessary nor desired. An artificially depressed water table provides considerable temporary ground water storage. Also, numerous temporary surface pondages will occur which cannot readily drain to the pump. This permits reductions in pumping rates over runoff rates ordinarily provided for free gravity outlet.

Storage (as used in this text) includes runoff that moves freely into the voids of the soil profile above the normal or regulated ground water level plus the runoff in transit that temporarily fills up channels, sloughs, and other discernible pondages, including the innumerable minor depressions scattered over the ground surface. Any such storage which is not directly connected with the forebay of the pump will reduce pumping peaks but may prolong the flow to be handled by the pumps.

Pumping rates also may be influenced by correlations of occurrence, depth and duration of flood flows and ground water levels with crop management, growth, and tolerance to inundation. High water and overflow in winter and early spring usually present no problem in northern latitudes. Flooding of one or more days has less effect on hay and grass crops than on general field crops, whereas pondages of 4 to 6 hours may destroy truck crops.

Pumping plant size may be another consideration in determining pumping rates in that at some size an added increment of capacity will increase overall

construction, operation, and maintenance costs disproportionate to the increment in derived benefits.

While daily runoff provides the primary basis for determining pumping plant capacity, seasonal distribution of rainfall and runoff may have considerable effect in the final analysis and yearly runoff is often useful in estimating annual operating costs.

When design pumping rates for large areas have not been established locally, or comparable rates are not available for establishing local rates, estimates of runoff to be pumped can be developed through hydrologic procedures. Runoff so determined should be compared with drainage coefficients used for gravity discharge for their validity since storage in the ground and in the innumerable small surface depressions and the course and rates of water movement to and from such storage and depression areas on extensive flat lands are less clearly defined and accountable than on more sloping topography.

Base flow is derived from seepage into the pumped areas from uplands, irrigation, and adjoining bodies of water. In most situations the amount of seepage is difficult to evaluate. Significant amounts from uplands can be reduced at some sites by interception and diversion of surface and shallow subsurface flows and thus be eliminated from consideration. When upland waters occur as artesian flow within the protected area, amounts can be determined according to procedures indicated in Chapter 4, Subsurface Drainage. If significant, such flow should be included in the discharge to be handled by the pumps.

Large amounts of seepage may occur, even with installations of interceptors and diversion drains, if the pumped areas have extensive borders along irrigation canals, rivers, large creeks, or lakes. The amount of seepage depends upon differences in elevation of water surfaces within and without the pumped area, the extent and permeability of underlying water-bearing strata such as sand and gravel, and the length and location of drains in contact with such strata. Seepage is often a major source of water in pumped areas along large perennial streams where large and prolonged head differences may persist between regulated or flood flow stages of the channel and low lying lands within the pumped drainage area.

Normally head differences in pumped areas adjoining large lakes and some coastal shorelines are so small or of such short duration that seepage rates are not significant and need not be considered in the pumping rate determination. However, wind driven tides in some coastal streams, estuaries and shore areas frequently persist for several days. This may cause enough seepage into the area at a time when gravity outlets are blocked to require its consideration in design.

Small surface areas

Where local experience for establishing pumping rates is lacking, pumping plant capacity for drainage areas up to a square mile in extent may be determined from applicable drainage coefficients or may be computed by simplified hydrologic procedures. When such hydrologic procedures are used, a time interval should be selected for which protection from storm runoff can be justified economically. Usually a 2-year frequency of occurrence for a 1-day duration storm is ample for hay and pasture land, 3 to 5 years for rotated cropland (general field crops), and 10 to 20 years for special high value crops (truck crops). Precipitation for the 24-hour or longer duration storm

of the selected recurrence interval may be obtained from records of the nearest weather station or as determined from U.S. Weather Bureau Technical Papers 40 (4) and 49 (5). The required pumping capacity should then equal the optimum runoff obtained from such precipitation in a 24-hour period or

$$Q = P_1 - S_g - S_c - S_f + q \quad (\text{Eq. 7-1})$$

Where Q = inches of runoff to be removed in 24 hours

P_1 = inches of precipitation from the 24-hour storm
for the selected frequency of occurrence

S_g = inches of precipitation in temporary ground storage

S_c = inches of precipitation in temporary ditch storage

S_f = inches of precipitation in temporary forebay storage

q = inches of base flow (when seepage is significant)

Since ground and ditch storage may not be available in a succeeding 24-hour pumping period if storm duration extends over several days, a check of two or more day storms needs to be made in determining the required 24-hour pumping rate.

For example, a 200-acre tract near Syracuse, New York is used to produce truck crops. Soils are sandy silt loams. The site lacks an adequate outlet and is without surface storage areas. It contains a system of parallel drainage ditches spaced 200 feet apart and averaging 4 feet in depth. What capacity pump should be provided?

10-year 24-hour rainfall (from Weather Bureau TP 40)	3.75 inches
Temporary ground storage (2-foot profile estimated at 1 inch per foot)	-2.00
Ditch storage	-0.33
Seepage	0.00
Runoff to be pumped in 24 hours	1.42 inches

Required pump capacity, Q_p , in gallons per minute, equals

$$Q_p = \frac{(\text{inches runoff})(\text{acres drained})}{\text{hours pumped}} \times 448.8$$

where 448.8 gallons per minute equals 1 acre inch per hour

$$= \frac{1.42 \times 200}{24} \times 448.8 = 5330 \text{ or say } 5400 \text{ GPM}$$

As a check on runoff, Curve No. 75, Table 10.1, NEH Section 4 (2) is selected as applicable to the site. Then runoff for Curve No. 75 in Figure 10.1 (Standard Drawing ES-1001) NEH Section 4 (2) is determined to be 1.50 inches. This is approximately equal to the value of 1.42 inches previously determined.

As a check on effect of loss in storage of a second 24-hour period of pumping for a multiple-day storm, runoff distribution for Type I storm from NEH Section 4 is determined to be about 66 percent in first day and 34 percent in second day. Then:

	<u>First Day</u>	<u>Second Day</u>
10-year 48-hour rainfall (from Weather Bureau TP 49)	2.71 inches	1.39 inches
Temporary ground storage	-2.00	0.00
Ditch storage	-0.33	0.00
Seepage	<u>0.00</u>	<u>0.00</u>
Runoff to be pumped in 24 hours	0.38 inches	1.39 inches

Thus required runoff to be pumped in second 24-hour period of a multiple-day storm does not exceed that to be pumped in the one day storm of the same frequency of occurrence.

Large surface areas

Where there are no established local pumping rates for large areas, hydrologic procedures may be used to develop the runoff to be handled by the pumps. Because high costs are involved when installing, operating, and maintaining large pumping plants, and also because less uniformity in the realization of full benefits is attained from large pumped areas, more specific economic evaluations need to be considered in such pumping rate determinations. A method for establishing such rates, through use of both hydrologic and economic factors, has been developed by Adams (6). This method relates, first, the pumping rates and storage to hydrologic factors of the area served by the pump. Next, it determines relationships of pumping rate to benefited acres and annual costs. Finally, pumping rates, annual pumping costs, and average duration of flooding are related to a prescribed sump elevation. See illustrated example in appendix A.

In developing the relationships of pumping rate and storage to hydrologic factors of the area served by the pumps, priority should be given to use of local stage, duration, and frequency records of runoff. If these are not available, then runoff may be determined from rainfall data such as the Weather Bureau papers TP 40 (4) and TP 49 (5).

Special areas

Formulas have been developed for determining the pumping plant capacity in a number of specified areas. These formulas are based on investigations and studies of installed facilities. Examples are:

Upper Mississippi Valley (as reported by Sutton) (3)

Maximum plant capacity may be determined as

$$C = 0.33 (G + 0.023r)$$

where C = plant capacity in inches per 24 hours

G = drainage coefficient for similar gravity drainage systems in inches per 24 hours

r = annual runoff to be pumped in inches

The value of r ranges from 5 to 12 inches per year for pumped areas having considerable gravity drainage, 13 to 16 inches per year for areas with moderate seepage and all runoff pumped, to 16 to 35 inches per year for areas with heavy seepage. The formula was developed empirically from observed data of pumped areas ranging between 6,000 and 52,000 acres and including both seepage and gravity flow. More precise values can be obtained from data compiled for individual pumping plants.

Florida (South Florida and Everglades, as established by the Everglades Engineering Board of Review) (3)

$$Q = \frac{69.1}{M} + 9.6$$

where Q = runoff in cfs per square mile

M = drainage area in square miles

This anticipates overflow from occasional heavy storms. Experience with pumping in Florida has established the need for capacities per 24 hours of 3 inches for 1 square mile, 2 inches for 2 to 3 square miles, and 1 inch for 10 to 16 square miles for truck crops in organic soils. A capacity of 1 inch per 24 hours is considered adequate for sugarcane and pasture land.

Subsurface drainage

Small areas of 100 acres or less may have outlets adequate for disposal of surface water but inadequate in depth and capacity for lowering water table and disposal of ground water. When direct entry of surface water can be excluded from forebay and sump, pumping plant capacity can be determined as the design capacity of a subsurface gravity drainage system plus some allowance for flows that may occur in excess of the design rate. Experience has shown an allowance of 20 percent as ample. Thus

$$Q_p = 1.2 \times Q_g \quad (\text{Eq. 7-2})$$

where Q_p = pumped discharge capacity

Q_g = gravity discharge capacity

Design capacity of the drainage system should be based on drainage coefficients prescribed in Chapter 4, Subsurface Drainage, or by local drainage guides. Where prompt removal of surface water is not provided by surface drains, increased subsurface flow may take place and thus require consideration of a higher coefficient.

Pumping Plant Design

Selection of pumps

In selecting pumps, consideration must be given to the type, characteristics, capacity, head, and number. At the same time an accounting must be made of their relationship with the economy of the whole pumping unit, including the type and size of the power unit, sump, structure, and the plant operation.

Pumps suited to most agricultural drainage conditions must operate efficiently while moving comparatively large quantities of water at low heads and also may be required to handle substantial amounts of sediment and trash in the

effluent. For these reasons either axial flow (propeller), mixed flow, or radial flow pumps are commonly used. All are types of the centrifugal pump. A typical propeller pump is illustrated in figure 7-2. Information may also be obtained from Chapter 8, Section 15, NEH (7), USDA Technical Bulletin 1008 (3), various pump manufacturers catalogs, Engineering Society papers and standards, and textbooks.

Axial flow, mixed flow, or radial flow centrifugal pumps essentially consist of an impeller mounted on a power shaft within a casing. Liquid is energized by the impeller blade through pressure and increased velocity within the casing which serves as a guide for flow into and out of the impeller.

Types of pumps

Axial flow or propeller pumps

The axial flow or propeller pump may be vertical or horizontal, with fixed or adjustable blades and with one or more stages in the pumping lift. The impeller consists of comparatively flat open blades on a small hub, similar to a ship's propeller, but which is mounted on a shaft within a pipe or tubular housing. Flow is axial or parallel to the shaft and is developed by the lift or push of the water by the angular blades as they are rotated in the water column. (See figure 7-3.) The angular set of the blades on the shaft determines the head and speed. Propeller pumps are more sensitive than radial flow pumps and best efficiency is obtained within a relatively narrow range of head. Pumps must be operated in the range of good efficiency or noise and cavitation can occur with resulting high operating costs. Adjustable blades are provided by some manufacturers which permit greater flexibility in operation through variation in discharge at constant heads, variation in head under constant discharge, and variable combinations of both head and discharge. Adjustable blades are particularly advantageous on large pumps when the power supply for starting loads is limited, when internal combustion engines are used, and when water stages fluctuate rapidly, as may happen when sudden upland storm runoff occurs or where limited forebay storage is a factor.

Propeller pumps may be obtained for dynamic heads of 3 to 25 feet, speeds of 100 to 1850 RPM and capacities exceeding 100,000 gallons per minute. The vertical, fixed-blade single-stage pump is applicable to most drainage system requirements and is the most extensively used. (See figure 7-2.) In addition to satisfactory operation at heads of less than 10 feet and a wide range in capacity, propeller pumps require no priming, are simple in construction, and generally are low in cost. Propeller pumps require a minimum amount of floor space and housing, where housing is needed. Because of their high operating speed, propeller pumps can utilize less costly high speed motors and engines. A disadvantage of these pumps is that the discharge drops off rapidly at heads above design head and horsepower can increase significantly at and near shut-off head. Another disadvantage is that they are not readily accessible for cleaning and repair. Although small units can be hoisted readily above the waterline, large units usually require gates and other devices as stop-logs for closing the sump and auxiliary pumps for dewatering it. Large size vertical pumps also may necessitate unusually deep sumps to provide sufficient submergence for protection against suction and vortex action which cause mechanical vibration and blade deterioration. Use of horizontal or mixed flow pumps usually permit shallower, less costly excavations and sumps but are themselves more costly and require priming equipment.

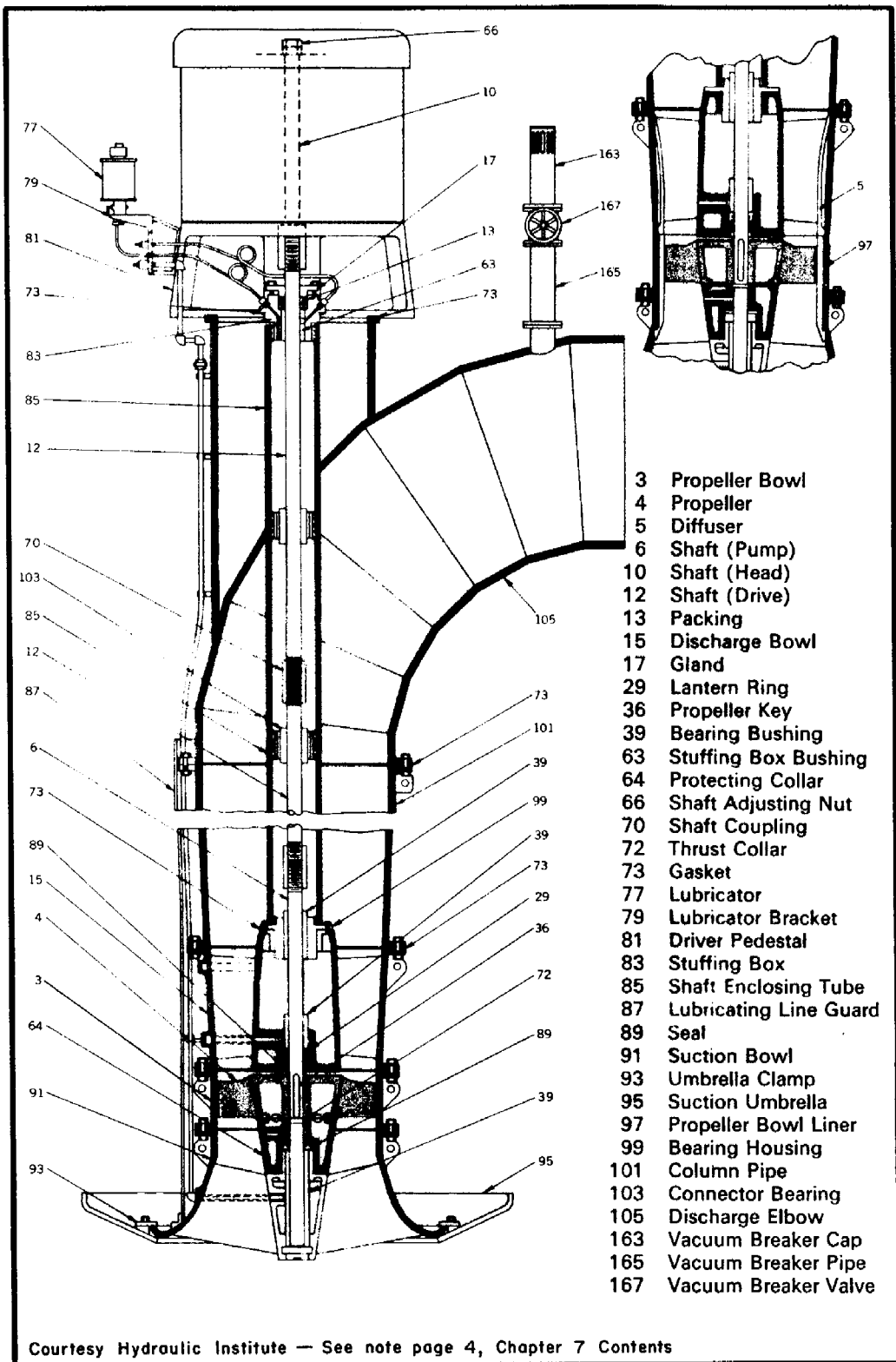
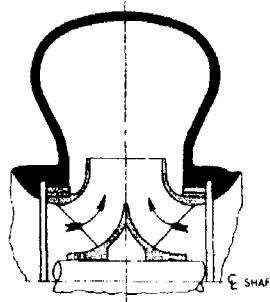

Figure 7-2, Propeller or axial flow pump

Radial Flow

A pump in which the pressure is developed principally by the action of centrifugal force. Pumps in this class with single inlet impellers usually have a *specific speed below 4200, and with double suction impellers, a specific speed of below 6000. In pumps of this class the liquid normally enters the impeller at the hub and flows radially to the periphery.



**Radial Flow Pump
(Double Suction)**

Mixed Flow

A pump in which the head is developed partly by centrifugal force and partly by the lift of the vanes on the liquid. This type of pump has a single inlet impeller with the flow entering axially and discharging in an axial and radial direction. Pumps of this type usually have a *specific speed from 4200 to 9000.

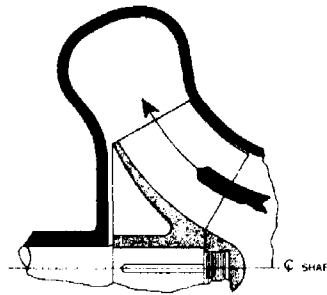

Mixed Flow Pump

Axial Flow

A pump of this type, sometimes called a propeller pump, develops most of its head by the propelling or lifting action of the vanes on the liquid. It has a single inlet impeller with the flow entering axially and discharging nearly axially. Pumps of this type usually have a *specific speed above 9000.

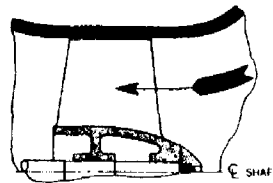

Axial Flow Pump

Courtesy Hydraulic Institute — See note page 4, Chapter 7 Contents

Figure 7-3, Classes of centrifugal pumps

Mixed flow pumps

Mixed flow pumps utilize both lift and centrifugal force to develop flow which is partially radial and partially axial. See figure 7-3. Some types of mixed flow pumps are quite similar to the propeller pump and the developed flow is largely axial. An open vaned propeller is used in which the blades are fixed radially around a conical hub and housed in a slightly enlarged bulbous section of the casing. These pumps will operate more efficiently over a wider range of head and at higher heads, 10 to 90 feet, than the straight propeller type. Mixed flow pumps are also constructed with volute type casings (spiral shaped with gradually enlarging cross section toward the discharge flange) and curved impeller blades in which flow at low heads is predominantly centrifugal. Mixed flow pumps have an advantage in starting over the axial flow pump when the power supply is limited. These pumps will also handle silt and the passage of small trash.

Radial flow pumps

Radial flow pumps operate efficiently at moderate to high heads (20 to 200+ feet) and in handling large amounts of sediment. See figure 7-3. Liquids enter the impeller by suction and with increasing velocity, move radially from the hub to the end of the blade and thence into the casing by centrifugal force. The thrust against the casing walls converts the developed energy into pressure head. Radial flow pumps are either volute or turbine. The volute pumps have the spirally expanded casing as previously explained. The turbine type contains fixed expanding vanes into which the liquid is first thrust on leaving the impeller for conversion of velocity to pressure head before moving into the discharge or last stage in the casing. Hazards of clogging make the turbine type undesirable for surface drainage but satisfactory in deep well drainage. Impellers of centrifugal pumps may be open, semiclosed, or closed. In the open type, the blades are exposed on all sides except where attached to the rotor. In the semiclosed type, blades are mounted on a shroud (disc wheel) attached to the rotor, leaving blades open on one side. Open and semiclosed impellers will pass sediment and small trash without clogging. In the closed type, blades are between twin shrouds leaving only the ends of blades open. This type may clog and wear excessively from sand and other fine materials in drainage water. However, the Francis impeller, a closed type used in mixed flow and some types of radial flow pumps, is well suited to drainage. In the Francis impeller the vanes are so shaped that as the blades cut into the column of entering water, the water is first moved axially before converting to radial movement.

Both single and double suction impellers may be cased in radial flow pumps. The double suction impeller is better suited for drainage because larger capacities can be handled for the same head, and end thrust on the pumps is opposed, thus dynamically balancing up the unit.

Figure 7-4 is a guide to selection of the type pump based on pumping head and quantity of water to be pumped.

Number of pumps

The size and number of pumps are determined from the required plant capacity. Many farm pumping plants will handle the total requirement with one pump. For large watersheds and where high value crops or farmstead improvements require flood protection, it is advantageous to have two or more pumps to provide efficient pumping over a wider range of pumping rates and so that a breakdown of one pump will not stop all pumping. Experience has shown that in a plant with two pumping units, the most desirable range in pumping rates

is obtained when one pump has about half the capacity of the other. When three or more pumps are used, equal capacity of all pumps usually is most satisfactory. When both subsurface and surface flow are to be pumped, one pump should be selected for efficient operation at the head and discharge required for pumping subsurface flow. In any case, it is desirable that the size of one pump is such that it can operate continuously over comparatively long periods without frequent starts and stops. Where pumps must operate over long periods of time, they should be selected for maximum operating efficiency. Optimum efficiency of pumps is not essential for the short periods of operation that usually occur at peak stage or discharge.

Pumping requirements

Performance of pumps

Performance of pumps varies with head, speed, discharge, and horsepower. The relationship and effect of these on efficiency of the pumping operation are established by actual tests or from tests of geometrically similar prototypes. These data are compiled as characteristic performance curves of the pump as illustrated in figure 7-5. The curves provide a basis for selecting the pump that will provide the most efficient performance for the required operating conditions. Usually such data are supplied by the manufacturer. Because of the difficulty of testing with large volumes of water, performance of most large pumps is forecast from tests on small models.

Total dynamic head

Total dynamic head on the pump is the static lift plus all the losses in the pump, suction pipe and discharge pipe. Total dynamic head can be expressed as:

$$H_t = \left(h_d + \frac{v_d^2}{2g} + d_1 \right) - \left(h_s + \frac{v_s^2}{2g} + d_2 \right) \quad (\text{Eq. 7-3})$$

in which

H_t is the net total dynamic head in feet of water.

h_d is the discharge pressure head in feet of water, measured near the discharge flange of the pump (gage pressure). It is positive if the pipe is under pressure and negative if under vacuum at the point of measurement.

v_d is the average velocity in feet per second in the pipe where h_d is measured.

d_1 is the elevation of the gage measuring h_d in feet above some reference plane. It is positive or negative, depending upon whether the gage is above or below the reference plane.

h_s is the suction head, measured near the suction flange of the pumps (gage pressure). It is nearly always negative, since the suction pipe is usually under vacuum.

v_s is the average velocity in the pipe at the point where h_s is measured.

d_2 is the elevation of the gage measuring h_s above the same reference plane used to determine the elevation of the gage measuring h_d .

PUMP TYPE SELECTION CHART

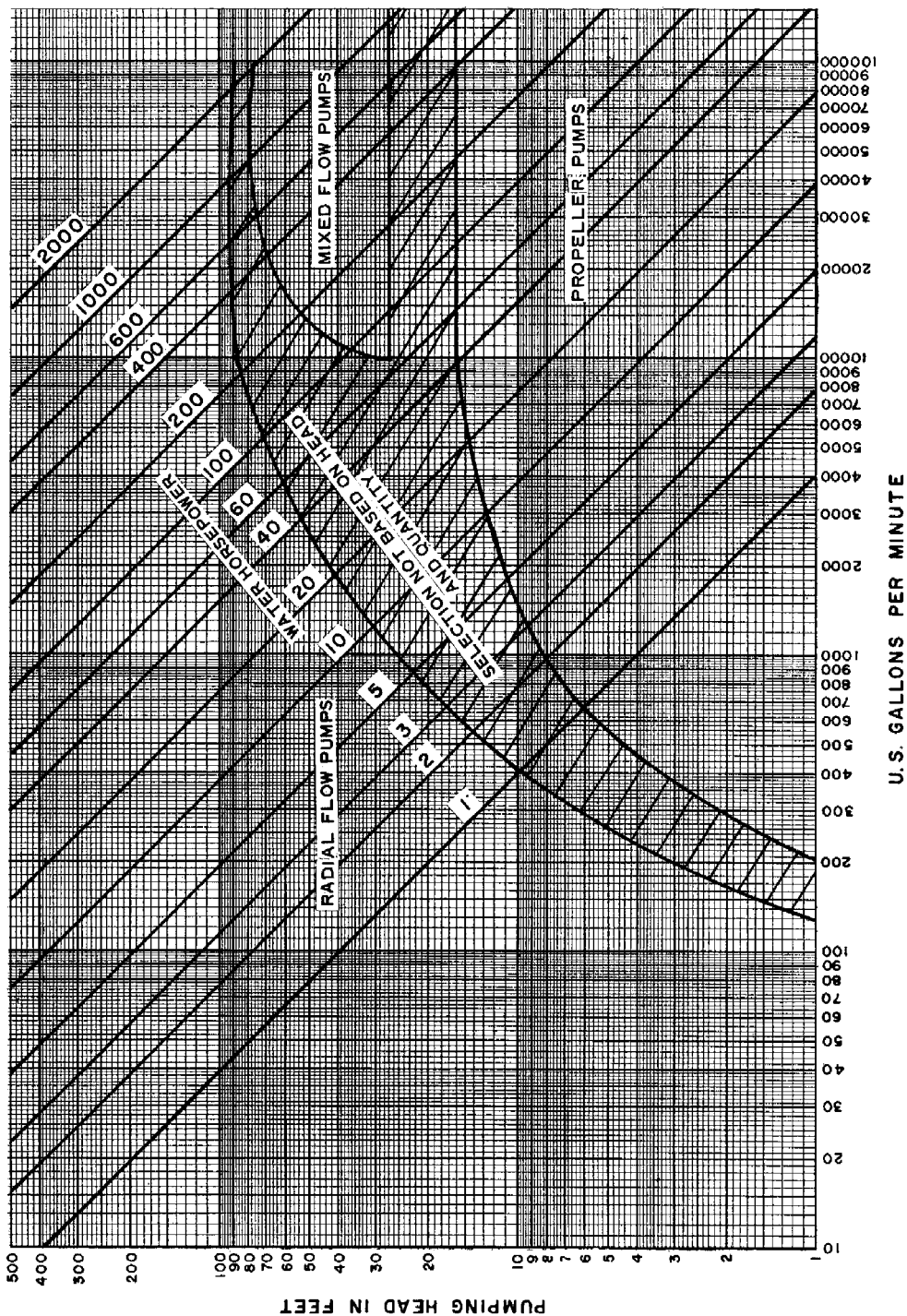

REFERENCE

U. S. DEPARTMENT OF AGRICULTURE
 SOIL CONSERVATION SERVICE
 ENGINEERING DIVISION - DRAINAGE SECTION

STANDARD DWG. NO.
 ES - 724
 SHEET 1 of 1
 DATE February 1971

Figure 7-4, Pump type selection chart

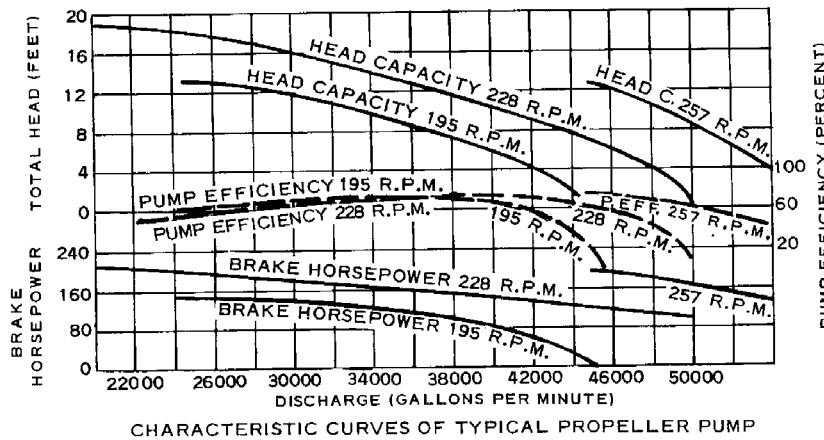
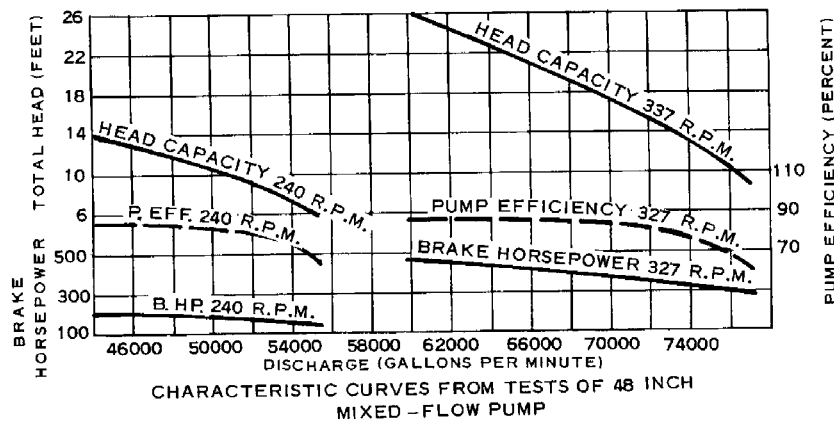
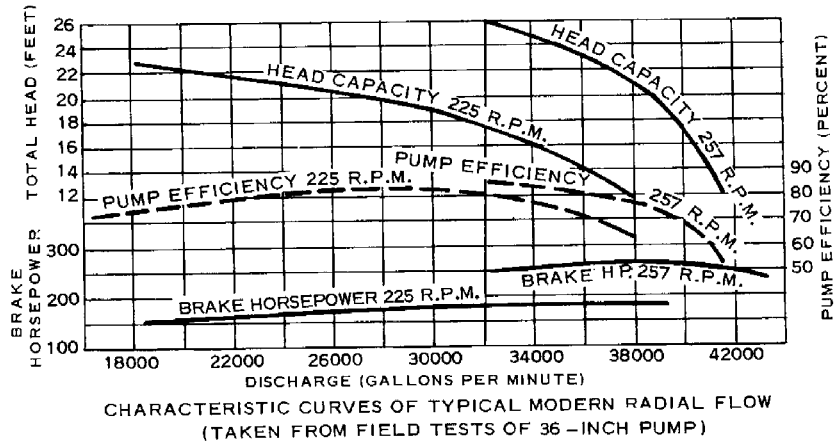

Reference:
USDA Bulletin 1008

Figure 7-5, Pump characteristic performance curves

g is acceleration due to gravity, equal to 32.16 feet per second per second.

Expressions $\frac{v_s^2}{2g}$ and $\frac{v_d^2}{2g}$ are velocity heads in the suction and discharge heads, respectively.

Actual internal head losses within the pump are hydraulic losses between the suction and discharge flanges. In well designed pumps these are quite small. They include disc friction and water shear in the sealing ring spaces; friction or shock in the volute or diffusion vanes of the impeller; and mechanical losses such as friction in the wearing ring and mechanical seal. An accounting of the head losses within pumps is usually covered by pump manufacturers' ratings.

Entrance, friction, and exit losses in the suction and discharge pipes dissipate a substantial part of the total energy used by the pumping plant.

Suction pipe head losses

Suction pipe head losses may be large unless proper attention is given to the shape and size of the suction pipe and the approach velocity of water entering the pipe, which is affected by the sump geometry and the effect of other pumps in the plant, if there is more than one pump.

Entrance losses at the suction entrance may be kept low by progressively expanding the diameter of the pipe from the pump flange toward the suction entrance or by flaring out the end of the suction entrance. Approach velocities in the sump to the suction pipe entrance should be kept under 3 feet per second. Normally, manufacturers provide a short suction pipe with flared entrance or bell on the vertical type axial flow and mixed flow pumps. Some manufacturers also add an umbrella or brim to the inlet edge to reduce further any entrance disturbance. Bells are often omitted on small propeller pumps made by local machine shops.

In order to avoid vortex action, flow in the sump toward the suction flange should be without swirls and ripples and as direct as possible. This is controlled primarily by the sump design and the maintenance of sufficient submergence over the suction bell so that vortex action does not develop. See criteria included under Sump Dimensions.

Net positive suction head (NPSH)

Net positive suction head is the total suction head in feet of liquid determined at the suction intake, corrected for datum and vapor pressure. Incorrect determination of NPSH can reduce pump capacity and efficiency and lead to cavitation damage.

$$\text{NPSH}_{(\text{available})} = h_{sv} = P_a - P_v + E - h_f \quad (\text{Eq. 7-4})$$

where P_a is atmospheric pressure at pump site in feet

P_v is water vapor pressure at operating temperature in feet

E is submergence of the pump intake in feet

h_f is suction losses in the suction pipe

P_a may be determined from table 7-1; P_v from table 7-2; E preferably from a manufacturer's pump catalog but also from (H-C) in figures 7-14 and 7-15; and h_f from the manufacturer's pump catalog. When the suction bell is attached directly to the suction bowl, losses are included in the manufacturer's pump curve and h_f then is not included in the equation. Temperature of drainage water will usually range between 50° and 70° F. and 60° is commonly used for design purposes.

For example: Given a Peerless pump with attached suction bell, 22,000 GPM capacity, installed at altitude of 4,000 feet, for water temperature of 60° F., determine the required NPSH (h_{sv}).

Referring to figure 7-15 and using value of E obtained from (H-C) in figure 7-14 for 22,000 GPM,

$$\begin{aligned} E &= (H-C) \\ &= 125 - 17 \\ &= 108 \text{ inches or } 9.0 \text{ feet} \end{aligned}$$

Referring to table 7-1, P_a for 4,000 feet = 29.2 and table 7-2 where P_v for 60° F. = 0.59,

$$\begin{aligned} h_{sv} &= P_a - P_v + E - h_f \\ &= 29.2 - 0.6 + 9.0 - 0 \\ &= 37.6 \text{ feet} \end{aligned}$$

Peerless model studies show that submergence of 6 feet 1 inch is sufficient to prevent vortexing. Thus the calculated net positive suction head indicates E could be substantially less than that used.

Discharge pipe losses

Discharge pipe losses include friction and exit losses. Losses can be computed from data in NEH Section 5, Hydraulics (8) or King and Brater's Handbook of Hydraulics (9). Friction losses in the discharge pipe can be reduced greatly by use of larger diameter pipe, usually 2 to 6 inches larger than the pump discharge flange. The transition can be made through a short expanding section of pipe at the pump flange. Figure 7-6 can be used to determine friction losses in steel pipe generally used for discharge pipe from drainage pumps. Head loss values in the chart are for riveted pipe and should be reduced 30 percent for welded steel or sheet metal pipe.

For example: Given a 20,000 GPM discharge through a 36-inch diameter pipe, determine the velocity head, velocity, and head loss.

Establish a reference point by entering chart in figure 7-6 at 20,000 GPM on left-hand vertical scale and moving horizontally across to intercept the discharge curve for the 36-inch pipe. Next, move vertically upward from the reference point to the velocity head curve and thence horizontally to the upper right-hand vertical scale. The velocity head is shown as 0.6 foot. Next, from the reference point move vertically downward to the bottom horizontal scale. Velocity is shown as 6.25 fps. Again from the reference point move vertically downward to intercept the head loss curve for the 36-inch pipe and thence horizontally to the lower right-hand vertical scale. The head loss is shown as 0.5 foot per 100 feet.

Table 7-1, Properties of water at various altitudes

Altitude Feet	Barometric Pressure		Atmospheric Pressure	
	Inches Hg		psia	Feet Water
-500	30.5		15.0	34.6
0 (Seasonal)	29.9		14.7	33.9
500	29.4		14.5	33.4
1,000	28.9		14.2	32.8
1,500	28.3		13.9	32.1
2,000	27.8		13.7	31.5
4,000	25.8		12.7	29.2
6,000	24.0		11.8	27.2
8,000	22.2		10.9	25.2

Table 7-2, Properties of water at various temperatures

Temperature Degrees F.	Vapor Pressure		Specific Weight pcf	Specific Gravity
	psfa	Feet Water		
32.0	12.7	0.20	62.42	.9999
39.2 ^{1/}	16.9	0.27	62.427	1.0000
50.0	25.6	0.41	62.41	.9997
60.0	36.8	0.59	62.37	.9990
70.0	52.3	0.84	62.30	.9980
80.0	73.0	1.17	62.22	.9966
100.0	136.0	2.19	62.00	.9931

^{1/} Temperature when specific gravity = 1.0000

VELOCITY HEAD, DISCHARGE, AND FRICTION-HEAD LOSS IN RIVETED STEEL PIPES

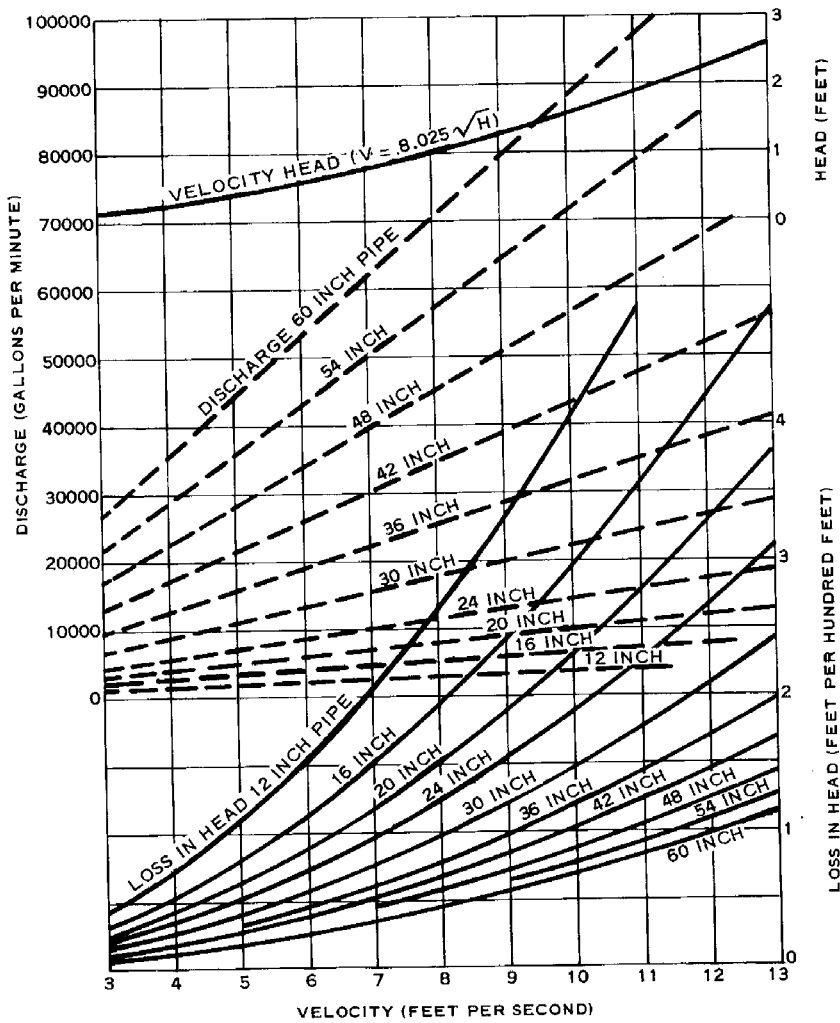

VELOCITY HEAD, DISCHARGE, AND FRICTION-HEAD LOSS IN RIVETED STEEL PIPES

Loss in head based on Scobey's formula

$$H = K_s \frac{V^{1.9}}{D^{1.1}} \quad \text{where } K_s = 0.51$$

For welded steel or for sheet metal pipe
3/16" or less thickness, reduce head loss
30 percent.

REFERENCE
U.S.D.A. Bulletin 1008

U.S. DEPARTMENT OF AGRICULTURE
SOIL CONSERVATION SERVICE
ENGINEERING DIVISION - DRAINAGE SECTION

STANDARD DWG. NO.
ES - 725
SHEET 1 Of 1
DATE February 1971

Figure 7-6, Head losses in riveted steel pipe

Head loss through a standard flap gate is quite low. Figure 7-7 contains values for various size gates and discharges based on tests carried out a number of years ago at the University of Iowa Hydraulics Laboratory by Floyd A. Nagler (10).

Specific speed

Specific speed expresses a relationship of head, capacity, and speed with respect to the suction lift. High speeds without proper suction conditions can cause serious trouble from vibrating noise and pitting. The maximum head in a single stage impeller is determined by the impeller diameter which establishes the peripheral speed and by the strength of the metal in the impeller casing to withstand such peripheral speed. Ordinarily, manufacturers limit peripheral speed to about 900 feet per minute to meet requirements of impeller castings normally used. By use of special high strength metals, impellers have been developed to withstand peripheral speeds beyond 14,000 feet per minute.

The Hydraulic Institute has defined specific speed and established standards which set upper limits of specific speed with respect to head, capacity, and suction lift as they apply to centrifugal pumps (1). Under normal circumstances, adherence to these standards assures freedom from cavitation. See figures 7-8, 7-9, 7-10, and 7-11. Figure 7-8 illustrates the characteristic profiles of several types of pump impellers ranging from the low specific speed radial flow designs to the high specific speed axial flow designs and their general location on the specific speed scales. Specific speed is defined as the revolutions per minute to which a geometrically similar impeller would run if it were of such size as to discharge 1 gallon per minute against 1 foot head. Specific speed, designated by the symbol N_s , can be determined from the following formula:

$$N_s = \frac{N\sqrt{Q}}{H^{3/4}} \quad \text{or} \quad N_s = \frac{N\sqrt{Q} H^{1/4}}{H} \quad (\text{Eq. 7-5})$$

where

- N = rotative speed in revolutions per minute
- Q = flow in gallons per minute at optimum efficiency
- H = total head in feet (total discharge head plus total suction lift)

and Suction Specific Speed, designated as S from

$$S = \frac{N\sqrt{Q}}{h_{sv}^{3/4}} \quad \text{or} \quad S = \frac{N\sqrt{Q} h_{sv}^{1/4}}{h_{sv}} \quad (\text{Eq. 7-6})$$

where N and Q are the same as above

h_{sv} = required NPSH in feet.

A pump with a high suction lift, say over 15 feet, requires special consideration in the pump design. This usually results in slow speeds and large pumps. If suction lifts can be reduced, smaller and cheaper pumps can be used.

HEAD LOSSES FOR LIGHT FLAP GATES

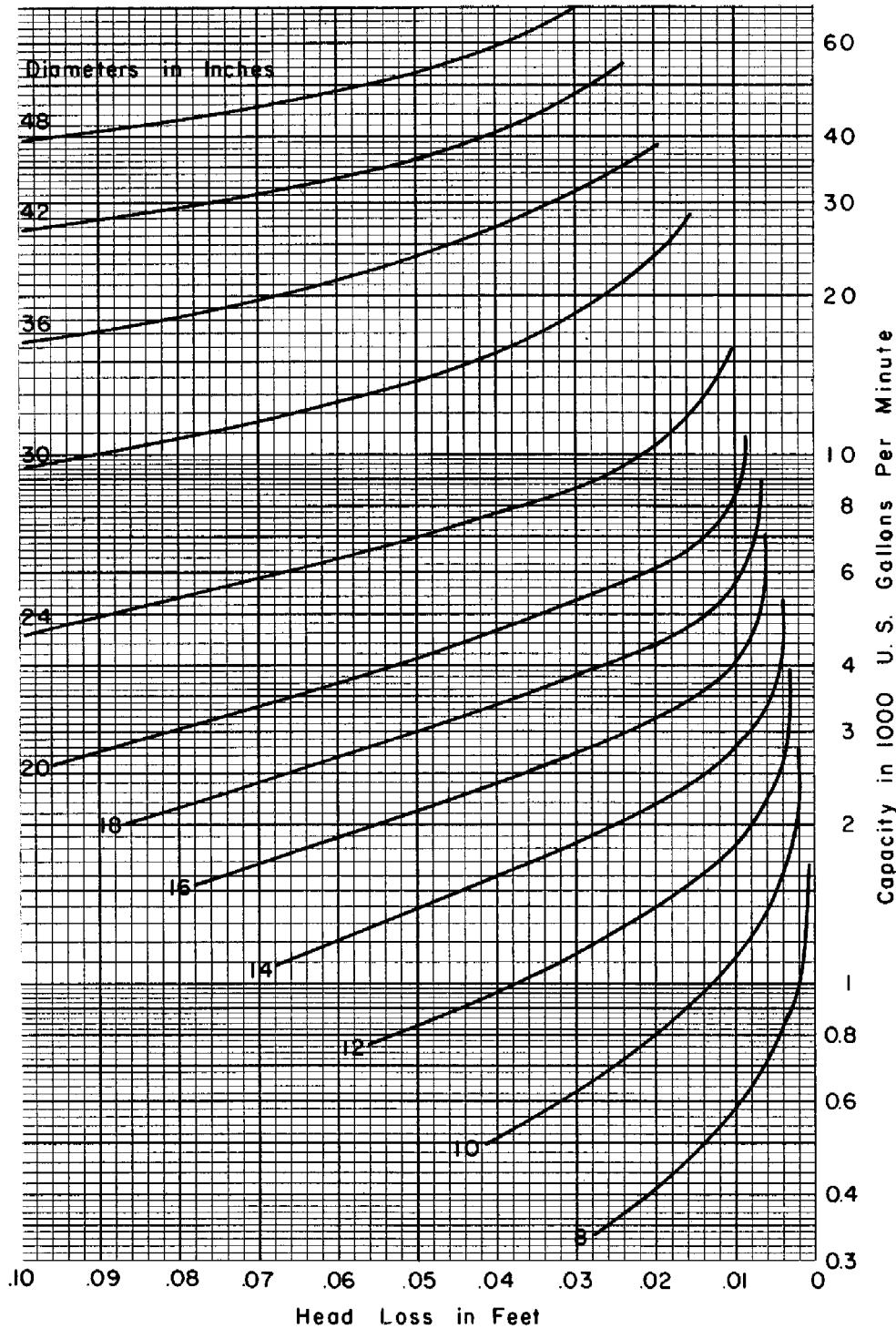

REFERENCE
 Handbook of Water Control
 1936 Edition
 W.Q. O'Neill Co
 Chicago, Illinois

U.S. DEPARTMENT OF AGRICULTURE
 SOIL CONSERVATION SERVICE
 ENGINEERING DIVISION - DRAINAGE SECTION

STANDARD DWG. NO.
 ES - 726
 SHEET 1 Of 1
 DATE February 1971

Figure 7-7, Head losses for light flap gates

Figure 7-8, Relationship of impeller design and specific speeds

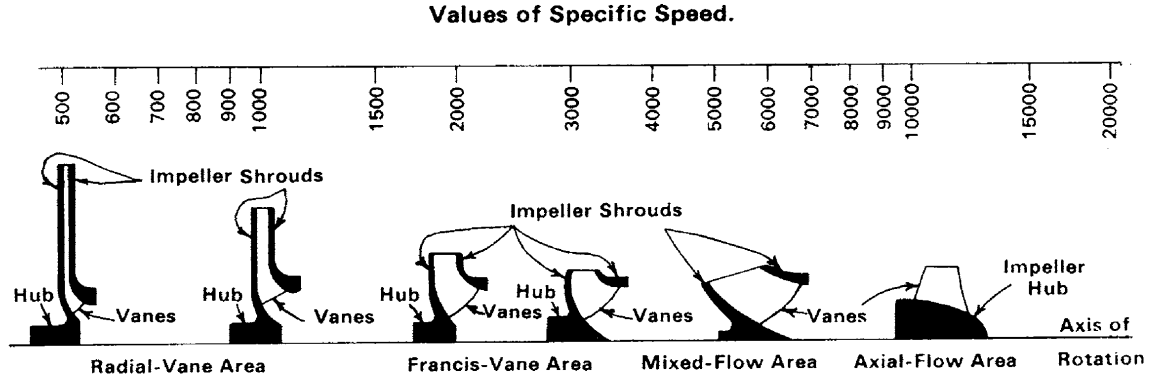

Courtesy Hydraulic Institute — See note page 4, Chapter 7 Contents

UPPER LIMITS OF SPECIFIC SPEEDS SINGLE SUCTION SHAFT THRU EYE PUMPS HANDLING CLEAR WATER AT 85° F AT SEA LEVEL

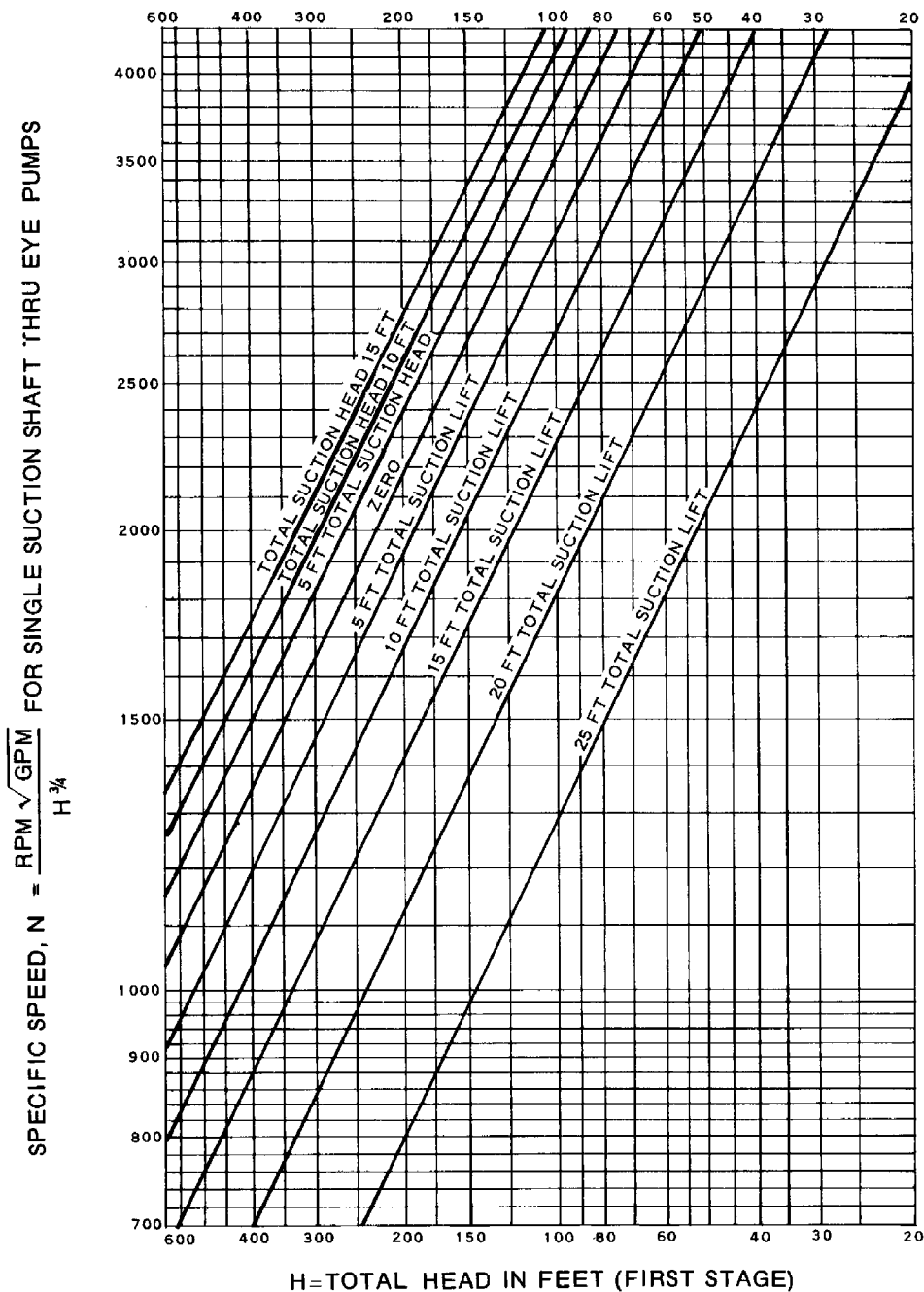

REFERENCE: Reprinted from Hydraulic Institute Standards 12th Edition. Copyright 1969 by the Hydraulic Institute, 122 East 42nd St. New York, New York 10017

U. S. DEPARTMENT OF AGRICULTURE
SOIL CONSERVATION SERVICE
ENGINEERING DIVISION - DRAINAGE SECTION

STANDARD DWG. NO.
ES - 727
SHEET 1 Of 3
DATE February 1971

Figure 7-9, Limits of specific speed, single suction, radial and mixed flow pumps

UPPER LIMITS OF SPECIFIC SPEEDS DOUBLE SUCTION PUMPS HANDLING CLEAR WATER AT 85° F AT SEA LEVEL

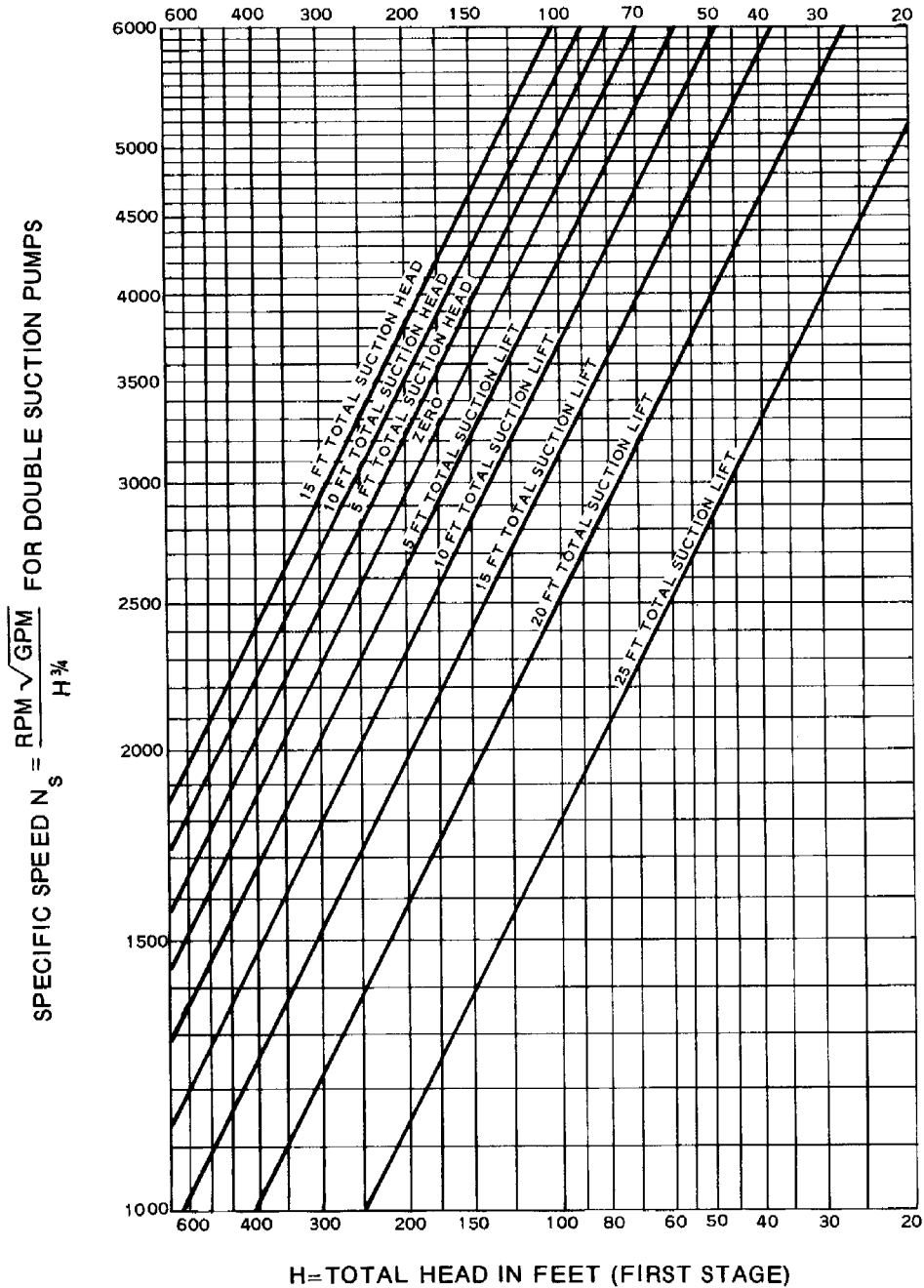

REFERENCE: Reprinted from
Hydraulic Institute Standards
12th Edition. Copyright 1969 by the
Hydraulic Institute, 122 East 42nd St.
New York, New York 10017

U.S. DEPARTMENT OF AGRICULTURE
SOIL CONSERVATION SERVICE
ENGINEERING DIVISION - DRAINAGE SECTION

STANDARD DWG. NO.
ES - **727**
SHEET 2 Of 3
DATE February 1971

Figure 7-10, Limits of specific speed, double suction, radial flow pumps

UPPER LIMITS OF SPECIFIC SPEEDS SINGLE SECTION, MIXED AND AXIAL FLOW PUMPS HANDLING CLEAR WATER AT 85° F AT SEA LEVEL

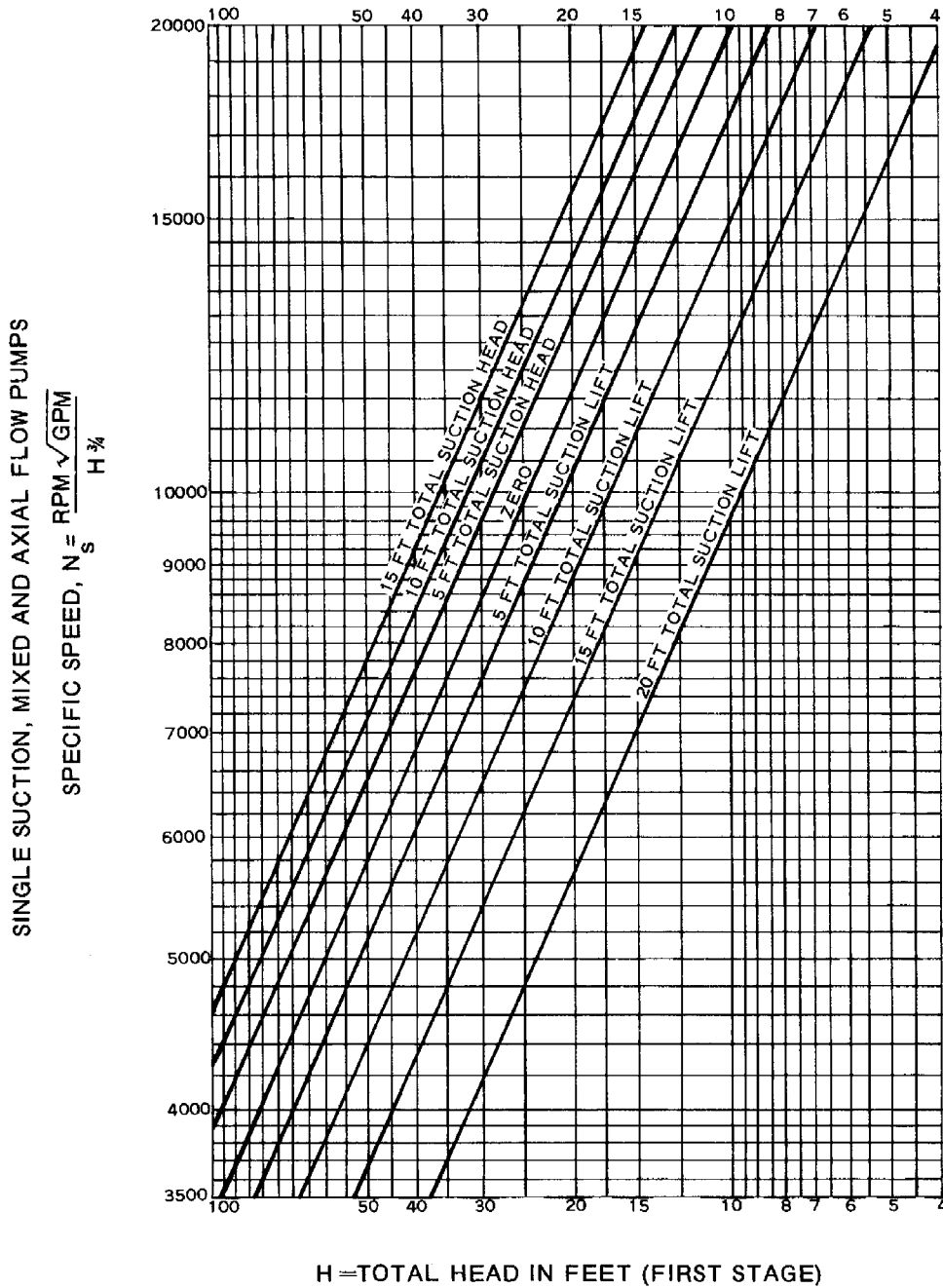

REFERENCE: Reprinted from
Hydraulic Institute Standards
12th Edition. Copyright 1969 by the
Hydraulic Institute, 122 East 42nd St.
New York, New York 10017

U. S. DEPARTMENT OF AGRICULTURE
SOIL CONSERVATION SERVICE
ENGINEERING DIVISION - DRAINAGE SECTION

STANDARD DWG. NO.
ES - **727**
SHEET **3 OF 3**
DATE **February 1971**

Figure 7-11, Limits of specific speed, single suction, mixed and axial flow pumps

Table 7-3 provides a useful guide for classifying pumps according to specific speed and the magnitude of pressure.

Table 7-3, Pump classification according to speed and pressure magnitude

N_s	Constant Speed and Capacity	Constant Speed and Pressure	Constant Capacity and Head	Head Range (in feet)	Type Pump
Low 2,000	high pressure	low capacity	low speed	200+	Radial or partial Francis type centrifugal
Medium 1,500-5,000	medium pressure	medium capacity	medium speed	20 to 200	Radial and Francis type centrifugal
High 4,000-9,000	low pressure	high capacity	high speed	10 to 90	Mixed flow or propeller
8,000-20,000				3 to 20	Propeller

Pump size

Pump size should be based on heads and speeds when the pumps are operating at or near maximum efficiency. Discharge velocities under these conditions will range between 9 and 13 feet per second for a properly sized pump. For purposes of establishing approximate size in the preliminary design of drainage pumping plants, 10 feet per second can be taken as most commonly applicable. The required pump size can then be computed by dividing the required capacity by the average discharge velocity selected. Table 7-4 gives pump sizes for various capacities and discharge velocities. With the pump size and static lift established, approximate suction and discharge heads can be computed.

Pump size can be determined on the basis of specific speeds from performance curves of tested prototypes or prototype models. These should be available for various types and sizes from leading pump manufacturers, government agencies such as the Corps of Engineers, Bureau of Reclamation, Soil Conservation Service, and others. Additional tests of performance should not be necessary except in unusual circumstances.

In the case of small pumps tests may be made directly. In the case of large pumps tests on similar small models can be made. Then, based on specific speeds and performance of such prototypes, the characteristics of the large pumps can be established accurately from the characteristic curve of size, speed, and submergence of the model. In most cases these are more accurately determined from direct field tests of a prototype because of the difficulty of obtaining accurate field test measurements when large volumes of water are involved. Model tests must duplicate closely the flow conditions in both suction and discharge to provide reliable prototype characteristics.

The following are the basic equations given by the Hydraulic Institute to correlate model and prototype values.

PUMP SIZE, CAPACITY AND DISCHARGE RATES

Pump Size Inches	DISCHARGE VELOCITY IN FEET PER SECOND				
	9	10	11	12	13
PUMP CAPACITY - CUBIC FEET PER SECOND					
10	5.0	5.5	6.1	6.6	7.2
12	7.1	7.9	8.7	9.5	10.3
14	9.6	10.7	11.8	12.8	13.9
16	12.6	14.0	15.4	16.8	18.2
18	15.9	17.7	19.5	21.2	23.0
20	19.6	21.8	24.0	26.2	28.3
22	23.8	26.4	29.0	31.7	34.3
24	28.3	31.4	34.5	37.7	40.8
26	33.2	36.9	40.6	44.3	48.0
28	38.5	42.8	47.1	51.4	55.6
30	44.2	49.1	54.0	58.9	63.8
36	63.6	70.7	77.8	84.8	91.9
42	86.6	96.2	105.8	115.4	125.1
48	113.1	125.7	138.3	150.8	163.4
54	143.1	159.0	174.9	190.8	206.7
60	176.7	196.3	215.9	235.6	255.2

Pump Size Inches	DISCHARGE VELOCITY IN FEET PER SECOND				
	9	10	11	12	13
PUMP CAPACITY - GALLONS PER MINUTE					
10	2,245	2,470	2,739	2,963	3,233
12	3,188	3,547	3,906	4,266	4,625
14	4,310	4,804	5,298	5,747	6,241
16	5,657	6,286	6,915	7,543	8,172
18	7,139	7,947	8,756	9,519	10,327
20	8,800	9,788	10,776	11,764	12,707
22	10,686	11,854	13,021	14,233	15,401
24	12,707	14,099	15,491	16,927	18,319
26	14,907	16,568	18,229	19,891	21,552
28	17,286	19,217	21,148	23,079	24,964
30	19,846	22,046	24,246	26,446	28,646
36	28,556	31,744	34,932	38,075	41,263
42	38,883	43,194	47,504	51,815	56,170
48	50,782	56,439	62,097	67,709	73,367
54	64,252	71,391	78,530	85,669	92,804
60	79,338	88,139	96,939	105,784	114,585

REFERENCE

U. S. DEPARTMENT OF AGRICULTURE
SOIL CONSERVATION SERVICE
ENGINEERING DIVISION - DRAINAGE SECTION

STANDARD DWG. NO.

ES - 728

SHEET 1 Of 1

DATE February 1971

Table 7-4, Pump size according to capacity and discharge velocity

If M represents the model and P the prototype then

$$\frac{\text{Specific Speed of M}}{\text{Specific Speed of P}} = \frac{\text{Diameter of P}}{\text{Diameter of M}} \cdot \sqrt{\frac{\text{Head of M in feet}}{\text{Head of P in feet}}}$$

and

$$\frac{\text{Capacity of M in GPM}}{\text{Capacity of P in GPM}} = \frac{\text{Diameter of M}}{\text{Diameter of P}} \cdot \sqrt{\frac{\text{Head of M}}{\text{Head of P}}}$$

Power and drives

Both electric motors and internal combustion engines are used as power units for drainage pumps. Primary considerations in selecting power equipment for drainage pumps are reliability of operation during times when pumps must be used, availability of power and fuel, initial and operation cost, annual use, and frequency and duration of pumping.

Electric motors

Electric motors are frequently preferred because of their simplicity and low upkeep. Vertical types are well suited to most drainage installations. Usually they can be connected directly to pumps without special transmission units and require little building space. Also, electric motors are easily adapted to automatic controls. However, consideration must be given to the possibility of discontinuance or interruption of power during severe storms. Also, power costs, both installation and operation, may be excessive, particularly in rural areas where high voltage lines are not readily available. Power costs may include both a primary charge based on capacity of the electric motors and a current charge based on the amount of current used. When the primary charge is the greater part of power costs, plant efficiency becomes less important than when a high kilowatt-hour charge is made.

Either a squirrel-cage (induction) or synchronous motor can be used for powering drainage pumps. These are obtainable in sizes and speed ranges meeting most needs. A squirrel-cage motor is the cheapest type of motor and is almost universally used on small to medium sized pumping installations using electric power. A synchronous motor is more costly but also slightly more efficient than the squirrel cage, requires less exact alignment on the shaft, and the power factor can be kept constant or varied. See figure 7-12 for generalized application ranges for two types of motors. Final selection should be based on a motor manufacturer's recommendations.

Starting torques are low on centrifugal pumps of the nonclog type. Starting torques are high on fixed blade propeller and mixed flow pumps and they are higher than the full load torque after the pumps are in operation. When limitations in starting current exist, or voltage regulation on incoming current is poor, squirrel cage motors, which have low starting torques cannot be used for the larger sizes of axial flow pumps except when such pumps have adjustable blades or when they are volute type pumps for which water can be depressed below the impeller during the pump start. In synchronous motors starting torques also depend upon a squirrel cage winding which is necessary in the initial stages of motor excitation and may cause high momentary loads in the powerline. Capacitors can be installed in the motors to adjust for incoming line voltage drops.

MOTOR SELECTION CHART

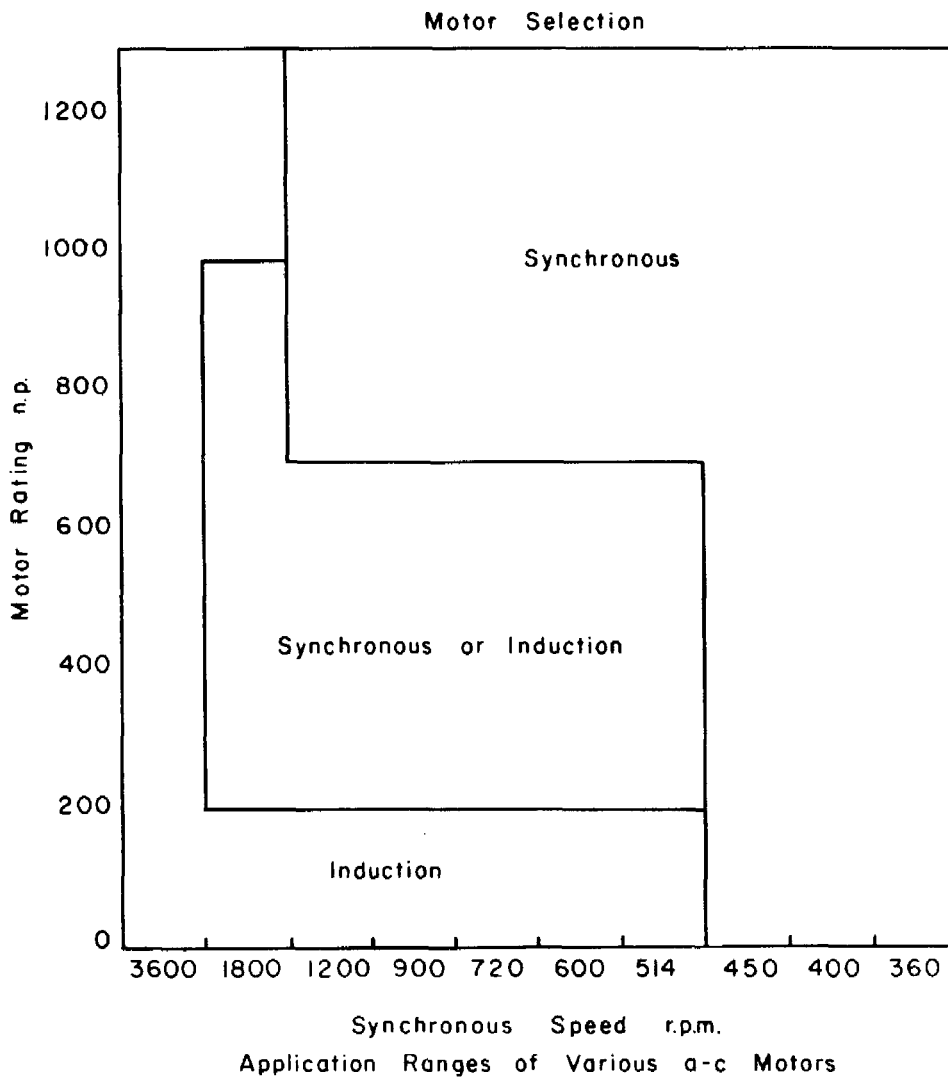

REFERENCE
 Pump Selection and Application by T. G. Hicks,
 page 308, McGraw - Hill

U. S. DEPARTMENT OF AGRICULTURE
 SOIL CONSERVATION SERVICE
 ENGINEERING DIVISION - DRAINAGE SECTION

STANDARD DWG. NO.
 ES - 729
 SHEET 1 of 1
 DATE February 1971

Figure 7-12, Motor selection chart

Internal combustion engines

Internal combustion engines may be gasoline, fuel gas, or diesel powered. Commercially available gasoline engines usually provide the lowest overall cost although operating cost is usually high. Diesel or fuel gas operation is usually more economical when annual operation exceeds 800 hours. Internal combustion engines are advantageous in that they can be operated at variable speeds, and with adequate fuel storage facilities are reasonably free from supply hazards of delivery failures during storms. Less deterioration occurs and less frequent engine check runs are necessary in diesel than gasoline units when long standby intervals occur between pump operations.

Power drives

Power drives for drainage pumps may be by direct connection, 90-degree gearbox, V or flat belt, and tractor power takeoff. Direct drive is limited to direct hookup of motor and pump with the same operating speeds. Hookup is by direct or flexible coupling and no loss in power is obtained. The gearbox is the most dependable and commonly used transmission for the vertical pumps and internal combustion engines. Combinations of gears are provided to permit both pump and engine to be operated at their most efficient speeds. Power loss through such connections is 5 percent or less. Multiple V belt drives, though less costly than the gearbox, are slightly less efficient with the power loss ranging from 5 to 10 percent. They are much more efficient than flat belts and can be operated satisfactorily in confined space with only short distances between pulleys. Flat belts are the least efficient, ranging from 20 to 30 percent power loss, depending upon the pulley type and size, slippage, and twist. They can be used with small pumps employing farm tractors for power. Tractor power takeoffs can be used in place of the flat belts but may require some gear or pulley type speed interchanging device to match the operating speed of the pump. There is usually a power loss of 10 to 15 percent in the gearing within the tractor.

Power requirements

The capacity of the power units is measured in horsepower. One horsepower is equal to 33,000 foot-pounds per minute, 2,545 BTU per hour, or 0.746 kilowatts.

Water horsepower (WHP) is the required output of the pumps.

$$\text{WHP} = \frac{QwH_t}{33,000}$$

where Q is discharge in gallons per minute
w is the weight of water in pounds per gallon
and H_t is total head of water in feet

$$\text{WHP} = \frac{Q H_t}{3,960} = 0.0002526 Q H_t \quad (\text{Eq. 7-7})$$

when weight of water at 68° F. is 8.34 pounds per gallon

Brake horsepower (BHP) is the power input of the pumps or is the required output of engines or motors, including power losses in power units and pumps.

$$\text{BHP} = \frac{\text{WHP}}{e_p e_t e_m}$$

where e_p is the efficiency of the pump, e_t the efficiency of transmission of power between engine or motor and pump, and e_m the efficiency of the engine or motor

therefore

$$\text{BHP} = \frac{0.0002526 Q H_t}{e_p e_t e_m} \quad (\text{Eq. 7-8})$$

Performance curves indicating engine and motor characteristics are available from most manufacturers. Performance curves are determined from dynamometer tests. Tests on engines usually are based on stripped down units without mufflers, cooling fans, etc. Loss of power from these accessories plus effects of continuous application of loads may require an approximate 20 percent increase in horsepower requirements over that shown by the manufacturer.

In estimating required horsepower to be used by the pumping units, efficiency of the several unit components (when in good condition and operated at rated capacity) can be taken as 90 percent for electric motors, 80 percent for diesel engines, 70 percent for water-cooled gas engines, 60 percent for air-cooled gas engines, 100 percent for direct connected transmission, 95 percent for gearbox transmission, 90 percent for V belt transmission, 80 percent for flat belt transmission, and between 65 and 80 percent for pumps.

For example, determine the required horsepower of a water-cooled gas engine, gearbox connected to a 10,000 GPM propeller pump operated at a 10-foot total head. The manufacturer's rating curve for the pump indicates an efficiency of 79 percent.

$$\begin{aligned} \text{BHP} &= \frac{0.0002526 \times 10,000 \times 10}{0.79 \times 0.95 \times 0.70} \\ &= \frac{25.26}{0.525} = 50 \end{aligned}$$

Thus an engine of rated horsepower twice water horsepower is required.

Since the pumping unit should operate satisfactorily under all operating conditions, characteristics of both pump and power unit should be considered for starting load, load at shutoff, and load for total heads less than the maximum.

Operating controls

Both automatic and manual controls may be used in the operation of drainage pumping facilities. Alternate manual controls must be provided where automatic controls are used.

The use of automatic start and stop controls are well suited to installations where short operating cycles are necessary, where the installation is remote, and where there is a shortage of competent operators. Automatic controls may deteriorate due to long periods of disuse and thus require frequent inspections and maintenance to assure good operation.

Short cycling as the result of water surface drawdown or water oscillation in the sump can be prevented by at least two methods. In the first method, locate the water level sensing device far enough upstream from the pumps so

that it is unaffected by local drawdown. In the second method, set the on-off levels sufficiently far apart so that local drawdown will not turn pumps off. If a minimum water level fluctuation is required, the first method is most suitable. If some fluctuation is allowable, the second method may be used.

Many devices are available for sensing water depths for automatic control. Among the most common are float type switches, electrodes, bubbler tubes, bells, and diaphragms. There are other electric sensors available, but they have not been widely adopted for drainage work.

In some locations, openings to automatic controls require screening against entry of small rodents or insects such as "mud" wasps, whose construction of nests in the equipment may prevent the functioning of the controls.

In areas where low temperatures are experienced protection against freezing may be necessary, such as a hinged gate or curtain enclosure of the sump opening above the waterline and heated well housing for float controls.

Float activated switches are perhaps the most common type of control used. The basic operation is that a float is suspended by a stainless steel tape which travels over a sheave to a counterweight. The sheave is connected to the meter switches. A change in the water surface elevation changes the position of the sheave, thus activating the switch. See figure 7-13. Adjustment of the water level settings are made at the switch. The float, tape, and counterweight are vulnerable to damage by debris, ice, and vandalism, thus enclosure in a well is usually necessary. The tape, sheave, and float must be of stainless steel or other corrosion resistant material. Algae, moss, and scum can foul the float and tape and prevent proper operation of the pumps. There is a definite physical limitation on how remote the switch can be from the float.

Electrodes are now used widely as controls. The basic operation is that the changing level of water completes or breaks electrical circuits, thus activating relays controlling the pumps. See figure 7-13 for a simplified schematic diagram. When the water level contacts the start electrode a complete circuit will occur through the relay through the water to the ground. The relay will close both contacts, starting the pump and also completing a "lock-in" circuit through the relay, the relay contact, and the water to the ground. Pumping will continue when the water level drops below the start relay because of the "lock-in" circuit. When the water level drops below the stop electrode the "lock-in" circuit is broken and the relay contacts open, stopping the pump. The relay will not be energized when the water level reaches the stop electrode because the relay contact is open. The cycle described will repeat when the water level reaches the start electrode. There are no moving parts in the water, therefore the chance of damage is less than for a float system. The electrodes can be placed remotely from the relay. Systems are available using very low voltage thus eliminating any chance of accidental shock. To change water level settings it is necessary to move the electrodes. Experience to date indicates electrodes currently available may become defective after several years in use and should be tested periodically to determine need for replacement.

The bubbler tube system is widely used in sewage treatment applications because of the inherent nonclogging operation. See figure 7-13 for a simplified diagram of operation. Air, or other gas, is bubbled slowly at a constant rate of flow through a small tube and discharged freely into the water at a fixed elevation. The pressure within the tube is that due to the depth of water

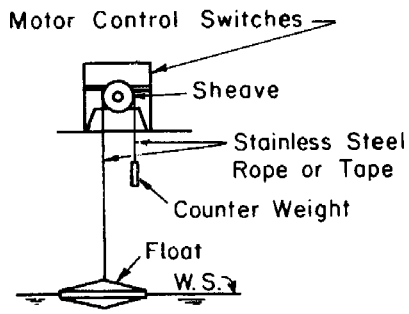

FLOAT CONTROL

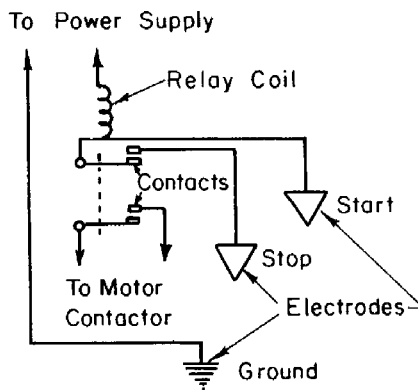

ELECTRODE CONTROL

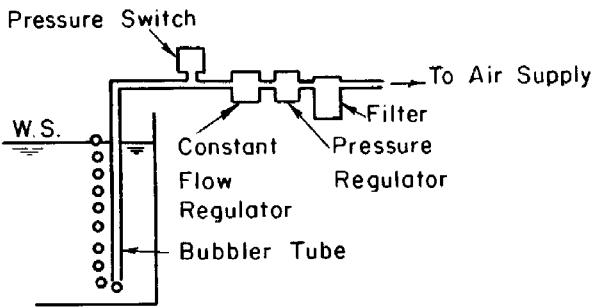

BUBBLER CONTROL

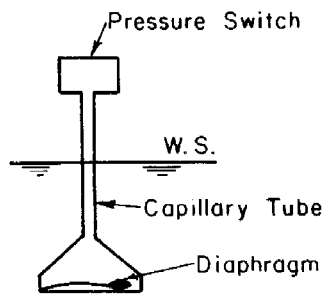

DIAPHRAGM CONTROL

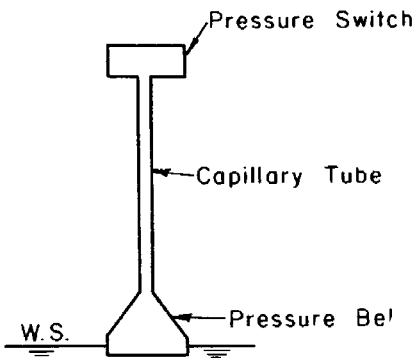

BELL CONTROL

Figure 7-13, Types of automatic control

over the end of the bubble tube. The pressure in the tube can vary as the water depth above the orifice varies. The air is supplied by an air compressor to a pressure tank. From the pressure tank the air passes through filters to remove oil, dirt, and water. A pressure reducing valve lowers the air pressure to a value which is slightly greater than that required for air flow at the maximum water level. The air then passes through a flow regulator valve which maintains a constant bubble rate regardless of the back pressure from the river. The air then passes the pressure activated switch and bubbles from the end of the bubble tube to the surface of the water. The air pressure variations caused by water depth changes activate the pressure switch thus controlling the pump. A pressure tank of nitrogen gas may be used instead of an air compressor. Nitrogen gas is often used because it is cheap, readily available, inert, safe, dry, and about the same weight as air in the atmosphere. If the bubble rate is kept low a 116 cubic foot cylinder will last about 1 year. The air line should be of small diameter. Almost any material can be used for the air line, including standard water pipe, copper tubing, plastic tubing, or hose. Small leaks in the line can be compensated for and will not interfere with proper operation. The switch can be remote from the bubbler tube. Water level adjustment is done at the switch. The diaphragm type of sensing device consists of a neoprene diaphragm placed across the opening of an air chamber submerged in water. See figure 7-13. An air line, called a capillary tube, extends from the air chamber to a pressure activated switch. An increase of water depth over the diaphragm causes the diaphragm to move into the air chamber, which causes the air pressure within the air chamber to increase. The increase of air pressure is transmitted to the pressure activated switch, which in turn starts the pump. There are no moving parts in this system, no air compressor or gas cylinder is needed, and the switch can be located at a point remote from the diaphragm. The smallest air leak will disable the system. Water level settings may be adjusted at the switch.

A bell type of system resembles an inverted water glass submerged in the water, with the air-water interface acting as the diaphragm. See figure 7-13. In all other ways the bell type system is the same as the diaphragm type system.

In larger sized pumping units and where internal combustion engines are used, manual starting with automatic shutoff will often prove to be advantageous. The operator must be present at each start in order to service and check equipment at beginning of operation. This should assure that equipment is in good operating condition and is serviced and checked for possible damage to pumps, motors, or engines not protected by safety devices.

Safety controls

A low level cutoff must be installed in each suction bay to prevent the possibility of the pump operating with an insufficient depth of water over the suction bell. Low water can occur if the pump control malfunctions or if trash plugs the trash rack. A time delay relay should be included in the low level cutoff circuit so that the pump must remain off for some given time. This time delay will prevent the short cycling which would occur with a plugged trash rack. In a multiple pump installation time delay relays should be included in each starting circuit to prevent simultaneous starting of electric motors after a power failure.

When pressure lubrication is used on the pump, motor, or gearbox a safety switch should be installed which will stop the motor if low lubrication pressure occurs.

Overload protection must be provided for all motors. A well designed overload relay will protect the motor against overheating from any cause, including short cycling, overloading, locked rotor, single phasing, phase reversal, and unbalanced phase voltages. Short circuit protection must also be installed. Protection against lightning should also be installed.

Experience has shown that all engines should be provided with safety controls even if not planned for automatic operation. A governor should be installed to regulate engine speeds. Cutoff devices should be provided to stop the engine if low oil pressure develops, excessive engine temperature develops, or if excessive speeds develop due to governor failure. Such automatic and manual engine operating devices should be supplied by the engine manufacturers.

Recorders and signaling devices

Automatically operated installations should have a signal device, such as a light, to show when pumps are operating. In a large installation with automatic operating controls a signal panel is desirable to show which safety control device stopped the pumps. This would save a great deal of time in locating the trouble. A recording indicator of running time of each pump could pinpoint short cycling, time of failure, and show which pumps are running at time of failure. Also, the record of running time would be useful in scheduling maintenance.

Sump dimensions

Sumps or suction bays for drainage pumping plants are contained in structures. Sumps may range from large open ended pits for handling large quantities of surface and subsurface water to small open or closed pits handling only the effluent from subsurface drains. The sump entrance must be large enough to pass the design discharge to the pumps without appreciable restriction. Maximum water level will be the optimum (design) stage in the sump. Level of the operating floor containing power units should be at high enough elevation above the optimum stage that inundation from all but extreme floods will not occur should pumps not be operating. The floor level also should be high enough above operating stage to provide protection against surge as might develop from sudden stoppage of the pumps and to provide clearance required for proper location and installation of suction and discharge pipes.

Minimum horizontal sump area will be that necessary for spacing pumps, installing suction and discharge lines, and controlling flow within the sump at velocities that will not cause appreciable turbulence or cross currents. The opening from the forebay storage area or channel should be aligned to avoid a change in direction of flow and be of sufficient size to keep the entrance velocity below 3 feet per second. The shape and dimensions of the sump should be such as to supply an even distribution of flow to the suction intake of pumps. This will avoid formation of large vortexes or cause low submergence that would permit entry of air into the pumps. Figures 7-14, 7-15, and 7-16 provide layouts, spacings and dimensions of sump and pumps for design of drainage pumping facilities. These are based on analysis of many installations but may require some modification to meet manufacturer's recommendations for the particular pump used.

SUMP DIMENSIONS VERSUS FLOW

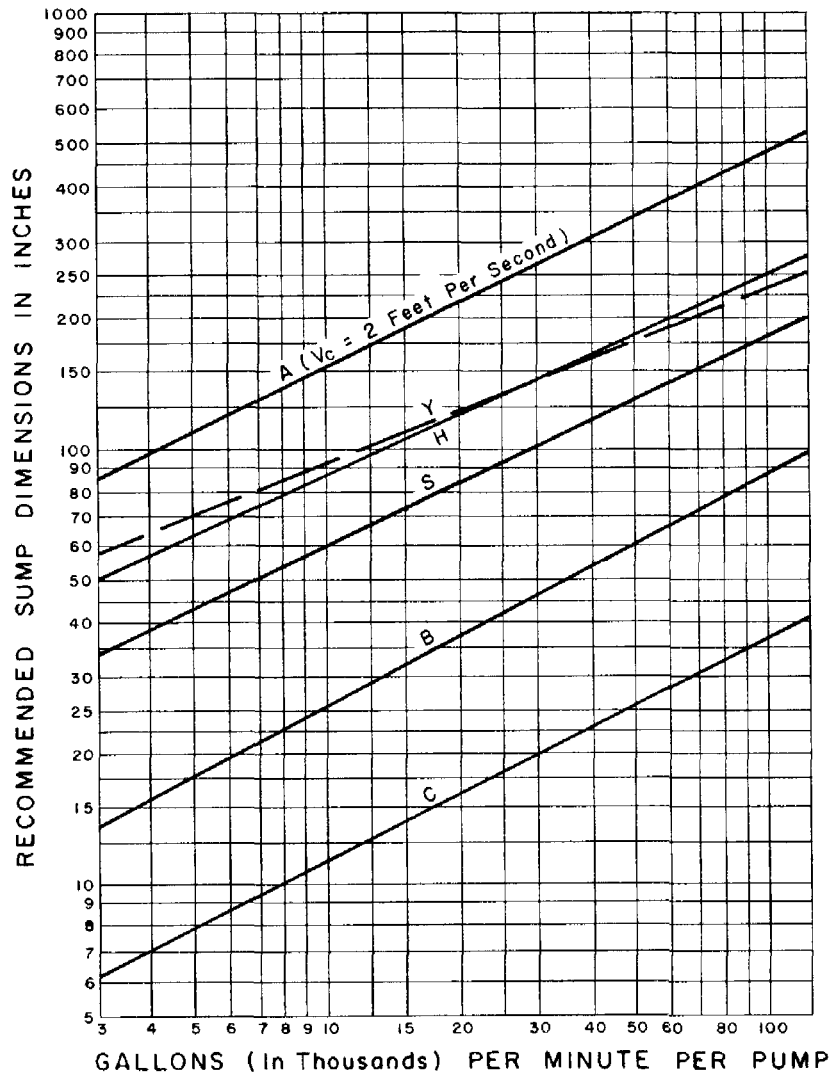

REFERENCE: Reprinted from
Hydraulic Institute Standards
12th Edition. Copyright 1969 by the
Hydraulic Institute, 122 East 42nd St.
New York, New York 10017

U.S. DEPARTMENT OF AGRICULTURE
SOIL CONSERVATION SERVICE
ENGINEERING DIVISION - DRAINAGE SECTION

STANDARD DWG. NO.
ES - 730
SHEET 1 Of 3
DATE February 1971

Figure 7-14, Sump dimensions versus flow

SUMP DIMENSIONS VERSUS FLOW MULTIPLE SUMP

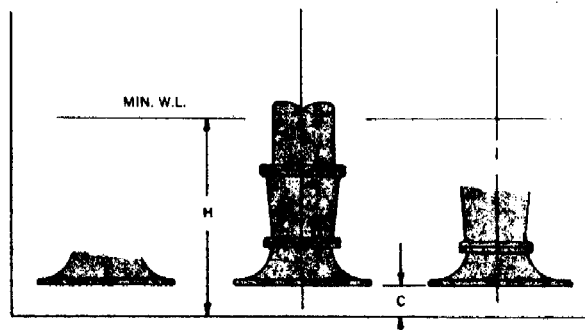
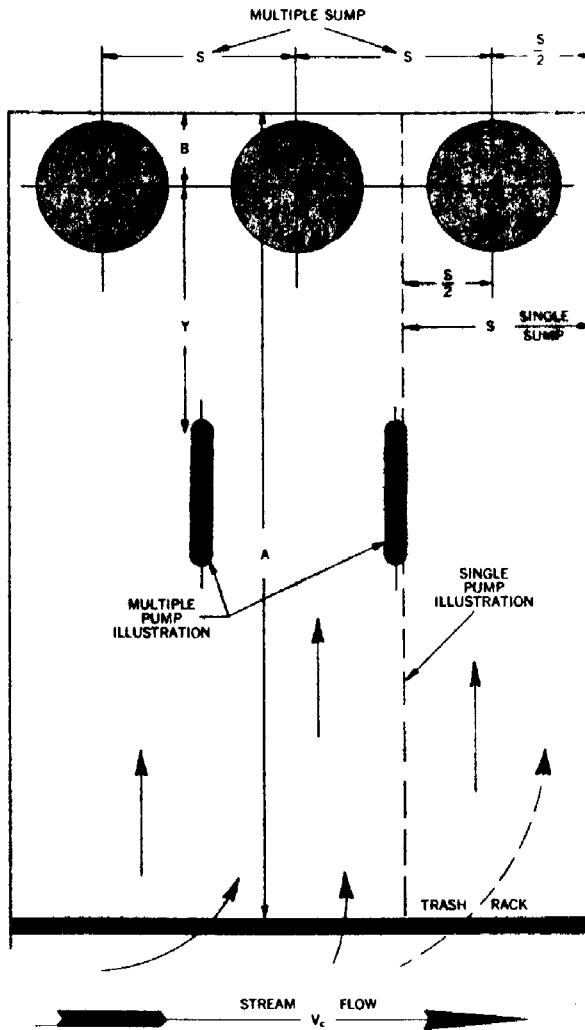

REFERENCE: Reprinted from Hydraulic Institute Standards 12th Edition. Copyright 1969 by the Hydraulic Institute, 122 East 42nd St. New York, New York 10017

U. S. DEPARTMENT OF AGRICULTURE
SOIL CONSERVATION SERVICE
ENGINEERING DIVISION - DRAINAGE SECTION

STANDARD DWG. NO.
ES - 730
SHEET 2 Of 3
DATE February 1971

Figure 7-15, Sump dimensions and pump arrangement

SUMP DIMENSIONS VERSUS FLOW MULTIPLE PUMP PITS

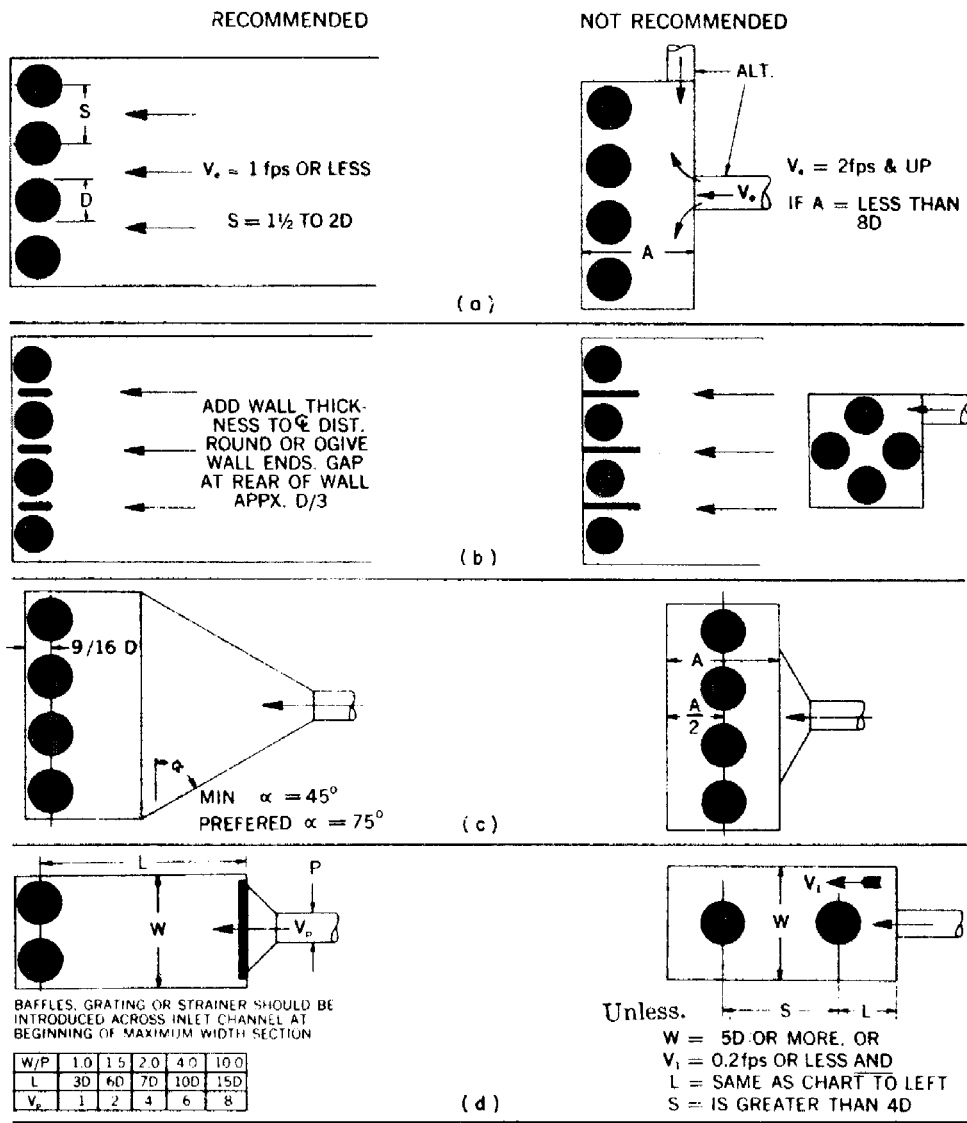

The Dimension "D" is generally the diameter of the suction bell measured at the inlet. This dimension may vary depending upon pump design. Refer to the pump manufacturer for specific dimensions.

REFERENCE: Reprinted from Hydraulic Institute Standards 12th Edition. Copyright 1969 by the Hydraulic Institute, 122 East 42nd St. New York, New York 10017

U.S. DEPARTMENT OF AGRICULTURE
SOIL CONSERVATION SERVICE
ENGINEERING DIVISION - DRAINAGE SECTION

STANDARD DWG. NO.
ES - **730**
SHEET **3** Of **3**
DATE **February 1971**

Figure 7-16, Sump dimensions and pump arrangement

Recommendations in figures 7-14 and 7-15 apply to both single and multiple pump installations. Dimension C could be slightly smaller or larger depending upon the manufacturer's recommendation. Dimension B is a suggested maximum which may be less depending upon suction bell or bowl diameters used by the manufacturer. The edge of bell should be as close as possible to the sump backwall but may be determined by required motor spacing on the floor or discharge pipe spacing in the sump. If this spacing is excessive, a false backwall should be used. Dimension S is a minimum for a single pump installation but can be increased. Dimension H is a minimum based on normal low water level at the suction bell, taking into consideration friction losses of a suction screen. This dimension can be less without damage to the pump if occurrence is momentary or infrequent. H represents the physical height of water level above the bottom of the suction inlet and is not submergence which normally is considered as H minus C. Dimensions Y and A are minimums. If a screen is not used at the suction bell, A should be larger. Screen widths should not be less than S.

Figure 7-16 illustrates additional considerations for multiple pump installations. Velocity should be low and flow simultaneous to all units in a straight line as shown in figure 7-16 (a). A number of pumps in the same sump operate best without separating sidewalls unless all pumps are always operating at the same time. If sidewalls must be used for structural purposes and pumps are operated intermittently, flow space should be left behind each wall as shown in figure 7-16 (b). Changes in size of inlet pipe or channel should be gradual as illustrated in figure 7-16 (c). The taper should be at an angle of 45 degrees or more and pumps located close to backwall to prevent large vortex areas. Pumps in line are not recommended unless ratio of pit to pump size is quite large and pumps are widely separated longitudinally. If pit velocity can be kept below a foot per second, an abrupt change from inlet pipe to pit can be accommodated when lengths exceed values shown in figure 7-16 (d).

Sump capacity

Total forebay and sump storage for the pump should be sufficient to prevent excessive starting and stopping of the pumps. Such storage is the volume of runoff and ground water in forebay and sump that will be removed between the start and stop levels in the sump. In large pumped areas most of the available storage must be obtained outside the sump from natural areas in or beyond the forebay. For comparatively small areas up to a square mile, available storage may be increased by ditch enlargement in the forebay area. For small acreages where only subsurface drainage will be pumped, available storage may be limited to the constructed sump.

Storage requirements depend upon pumping rate and frequency of cycling. When the inflow rate is less than the pumping rate, cycling will occur. For manually operated pumps the number of stops and starts should not exceed two to three cycles per day in consideration of operator convenience. For automatically operated pumps the number of cycles per unit of time should not exceed the manufacturer's rating. Based on University of Minnesota Studies by Larson and Manbeck (11) on small sumps where cycling is frequent, efficient operation can be obtained for electrical motor driven pumps with 10 to 15 cycles per hour.

Time of one pumping cycle equals the time it takes to empty the storage in the sump and the inflow during the emptying process, plus the time it takes for inflow to refill the sump after the pump has stopped. This is expressed in the following equation.

$$\frac{60}{n} = \frac{7.5 S}{Q_p - Q_i} + \frac{7.5 S}{Q_i} \quad (\text{Eq. 7-9})$$

where

n = number of cycles per hour

S = storage volume in cubic feet

Q_p = pumping rate in gallons per minute

Q_i = inflow rate in gallons per minute

7.5 = conversion factor for gallons to cubic feet

At maximum storage

$$Q_i = \frac{Q_p}{2}$$

$$\text{and } S = \frac{2Q_p}{n}$$

Generally sump sizes should be such as to provide at least 1-foot depth in open pits and 2-foot depths in closed pits between starting and stopping levels of the pump.

Closed sumps may be constructed of concrete, concrete block, silo staves, corrugated metal or metal tanks. Rectangular shapes are recommended, although the circular shape is satisfactory for small systems and is more economically built. At higher velocities some rotation and turbulence can develop in the circular sump. The sump should be checked for uplift. Most serious conditions occur when the sump is pumped down and the surrounding soil is saturated. Structural design and construction of large sumps must be based on site conditions on an individual job basis and is not covered in this text.

Stop logs

Stop log gates should be provided for the sump openings so the sump can be dewatered for pump repairs or cleaning. Slots should be made in the end walls of the opening or passageway walls for placing the stop logs. Stop logs may be seasoned timber or wood faced I-beams with strength to withstand imposed fluid pressures and treated against rot, insect damage, and corrosion. Provision should be made for convenient handling and storage when not in use.

Trash racks

Trash racks should be provided to screen out trash and debris from surface flows entering sumps. Strainers or screens mounted on the bell or suction flange should be avoided since they tend to clog and are hard to clean. The trash rack should be located across the entrance of the sump and inclined toward the structure in such manner that flow moves evenly through the rack and collecting trash and debris tends to float up toward the water surface where it can be easily removed by rakes. Bar screens should be used in which the clear space between bars is within the range of 1 1/2 to 3 inches. The total clear flow area of the rack should be sufficient to keep the velocity through the rack under 2.5 feet per second. Trash racks should be located

outside of the pumping plant structures to facilitate removal of trash. Racks should be removable or hinged so that if it becomes necessary they can be raised above the floor and blocked open when pumps are not in operation. In most cases raking will be done by hand and a suitable platform with guardrail should be provided for safety in collecting and disposing of the trash and debris. A log boom or float, anchored upstream from the entrance, may be needed where timber or large floating debris is a problem.

Discharge pipes

Discharge pipes usually will be located under, through, or over a protecting structure, which is usually an earthen dike. Steel pipes, adequately protected from corrosion, are best suited and almost universally used for this purpose. Flexible couplings should be provided where the pipe passes through the sump or walls of the pump plant structure and where sharp bends are placed in the line. Thrust rods must be installed at the elbows of a vertical pump to prevent movement of the pump. Flexible couplings allow for structural settlement and expansion or contraction of the pipe. Sharp bends in the line should be avoided. Use of a separate pipe for each pump is desirable, with the pipe connected directly to the pump discharge flange. Thrust blocks may also be required at changes of alignment.

Discharge pipes may be installed through or over the wall or embankment. Pipes through the structure are advantageous in that sharp bends can be avoided but are subject to back pressure and possible backflow when the pumps are not in operation. When pipes are installed below the high water level on the discharge side of a dike, special precautions must be taken to prevent piping along the conduit. Flap gates of good quality must be provided to protect against backflow. A hydraulically cushioned flap gate should be used if the flap gate is within a few feet of the pump or the water depth is several feet above the flap gate. Gates should be so located that silt and debris will not accumulate, particularly during periods when the pumps are not in operation, and thus obstruct gate operation. Pipes ordinarily are supported by the dike embankment with projections on the discharge end, either in a headwall structure or on pile bents which should also support directly the weight of the flap gates. Unless a suitable headwall structure is used, the pipe should project a sufficient distance beyond the dike face to provide protection from erosion or eddy currents. Where amount of discharge is large, riprap protection of the embankment is necessary. All conduits through dikes below the maximum high waterline must be connected to the pump with a flexible coupling and provided with anti-seep collars designed to increase the seep line distance along the conduit by at least 15 percent.

Pipe backflow can be eliminated by placing the conduit over the top of the wall or dike. This is particularly applicable in the case of small pumping units or where pumping at higher heads is of such short duration that operating costs are not affected materially. Much of the pumping head can be recovered if such lines over the dike are extended and lowered on the water-side of the embankment so as to operate as a siphon. This is particularly advantageous where extensive pumping is done at high heads. Flap gates must be provided to protect against stoppage of the pump and backflow caused by reverse siphoning. Siphon breakers should be installed in the pipe to prevent backflow.

An air vent in the high point of discharge pipes is desirable in preventing excess back pressure when starting pumps. Mounding earth over pipe on dikes is desirable as protection against pipe displacement and erosion of the dike

surface when high flood stages occur. Such mounding also permits establishment of crossings for maintenance equipment and vehicular traffic.

Housing

Housing is usually needed for pumps, prime movers, and operating controls, to protect them against weather, moisture, and vandalism, and to provide suitable working area for manual operation, maintenance, and repair work. In some situations where sealed motors, enclosed engine and transmission units, etc. are used, such housing may be omitted. In any case, storage should be provided for tools, supplies, operation and maintenance manuals and records.

Housing usually consists of a superstructure or building over the operating floor above the sump. The structure should be fire resistant and conform to local building codes when these exist. Adequate ventilation is essential for internal combustion engines. In the case of large pump units sufficient floor clearance and special openings, such as doors or removable panels in sidewalls and roof, should be provided. Normally, gantry cranes are installed as permanent equipment for large pumping units. For small units hoisting equipment may be omitted where motor cranes can be obtained when needed for this purpose.

When engine-driven fan cooling systems are used, necessary ventilation of the building is provided through automatically controlled louvers. Air intake louvers should be installed with greater capacity than exhaust louvers to protect against reduction of air pressure within the structure below atmospheric pressure. Where feasible, radiators should be mounted so heat can be removed from the building directly through the wall or through exhaust ducts.

Particular attention should be given to protection of wiring and control equipment against corrosion from moisture and fumes. Wiring should be enclosed in corrosion-resistant conduits and control boxes.

Equipment such as switches, floats, and tapes should be of corrosion-resistant metal. Floats should be encased in wells with an opening near the bottom of the sump so as to minimize effect of surges. Temperature and moisture in the well may be controlled by means of an electric bulb.

When fuel storage tanks are used, National Board of Fire Underwriters and local jurisdictional codes should be followed in the installation and supply of the tanks. Tank size should be determined on the basis of storage required for maximum rates of operation over the anticipated pumping period and consideration of access of the source of supply to the pumping facility. Storage for a 3-day operating supply should be the minimum provided, and this should be increased to meet adverse delivery and operating conditions.

Pumping installations should be provided with fences and railing to protect operators and the public from hazards such as pits and dropoffs. Protection of operators from moving belts and drive shafts, engine exhaust pipes, and electric currents should be provided through use of guards, covers, and warning signs. Gates and doors with locks should be provided to prevent unauthorized operation and vandalism.

Since pumping plants are usually unmanned for a large part of the time and are often remote from habitations and roads, use of exterior lights and sound warning systems at the structure or remote monitoring station, activated by sump floats or the pump starting system, are a desirable feature in assuring timely attention of the responsible operator.

Field Tests of Drainage Pumping Plants

Field tests of new drainage pumping plants check performance of pumping units against design and specifications. Tests of operating plants are desirable at intervals to determine operating efficiencies.

The discharge of water in pipes may be measured with a probable accuracy of 5 percent by use of Tulane pitot tubes, discussed in the following section.

Procedure for field tests

Surveys and gages

Temporary staff gages in the suction and discharge bays should be established using assumed or sea level datum as zero on gages. However, legible gages which exist may be used with elevations checked to nearest 0.01 foot.

Elevations on the same datum as the staff gages should be obtained of the following:

1. Floor of suction bay.
2. Entrance lip of suction pipe.
3. Centerline of pump, motor, and engine shafts.
4. Elevations of each pump, engines, motors, suction and discharge pipes so that an accurate plan and profile may be drawn of each pumping unit. Manufacturers' catalogs may be consulted to obtain dimensions.
5. Elevation to nearest 0.01 foot of the centerline of each hole tapped in suction, discharge pipe, or pump.
6. Diameter of pipe to nearest 0.001 foot at each hole tapped in suction or discharge pipe or pump, including the hole where pitot tube or piezometer is inserted.
7. Diameters and lengths to nearest 0.01 foot of tangents and bends of the suction and discharge pipes.

Total head on pump

The total head on the pump is determined by measuring the discharge head close to the discharge flange of the pump, the suction head close to the entrance of the pump and correcting for differences in velocity head and elevation of points of measuring.

The total head on the pump is equal to the total energy in the water at the discharge flange minus the total energy at the suction flange of the pump. It is expressed by Equation 7-3 where total head equals static lift plus the losses in the suction pipe, the losses in the discharge pipe, and the velocity head. (See section on "Total dynamic head" under "Pumping Plant Design.")

Where the pump is submerged it may not be feasible to measure the suction pressure head, h_s . In such cases the total head may need to be estimated by measuring the discharge pressure head, h_d , and estimating the suction pressure head by taking into account the estimated entrance loss of the suction

pipe and the friction losses in the suction pipe. King and Brater's Handbook of Hydraulics (9) and NEH Section 5, Hydraulics (8) explains how these losses may be estimated.

Measurement of h_d and h_s in the field are accomplished by the following procedures:

Tap, ream and thread a hole in discharge pipe to take a standard 1/4 inch pipe nipple, which should be about 4 inches long. (See figure 7-17.) One hole should be located at centerline of pipe from 4 to 18 inches from the pump flange. A valve, rubber hose and glass tube are attached as shown in the figure. If flow is unusually turbulent at this point as indicated by the preliminary tests, it may be important to drill additional holes at top and both sides or on 45° diameters to obtain an average reading around pipe.

A standard globe valve screwed on the pipe is opened when readings of the pressure head are taken and closed after readings are made.

At least one more nipple is required to connect with a rubber hose which will fit over a piece of glass tubing. Glass tubing having an internal diameter of 1/8 to 3/16 inch is recommended. The rubber hose should fit over the glass tube. A 1/4 to 1/8 inch reducer between the valve and rubber hose permits one end of the hose to be fitted over a short 1/8 inch standard nipple.

Discharge measurements

In making field tests of drainage pumps a measurement of the discharge should be obtained within the required accuracy. Measurements may be accomplished by a Tulane pitot tube within 5 percent accuracy.

In order to obtain the most accurate results, the following test conditions are desirable:

1. A straight length of pipe in which uniform flow conditions exist. Tangents should be at least five times the diameter.
2. The pipe running full of water during test.
3. Pipes on horizontal tangent but sloping pipe may be used.
4. Approximate measurements by current meter which are adequate for determining operating efficiency of the pumping unit. Such measurements probably provide discharge readings within 10 percent accuracy. This may be used as a basis to determine if the efficiency is unusually low and whether the expense of the pitot tube measurements is justified.

In many farm pumping plants, a sufficient length of discharge pipe is not available to obtain accurate pitot tube measurements, the pipe does not run full of water, or the pipe is inaccessible. Under such conditions, measurements by weir, orifice, flume (Parshall), or channel water measuring device should be considered. Measurements of discharge by these methods are described in hydraulic texts and will not be discussed herein.

Discharge measurements with Tulane pitot tubes

After the point of measurement is selected as described above, the following procedure is used in making a discharge rating.

DRAINAGE PUMPING PLANT FIELD TESTS SUCTION AND DISCHARGE GAGES

Measure height (h_d) of water in feet where pipe is under pressure.

Where discharge is under vacuum, set up mercury gage as shown on suction side of pump.

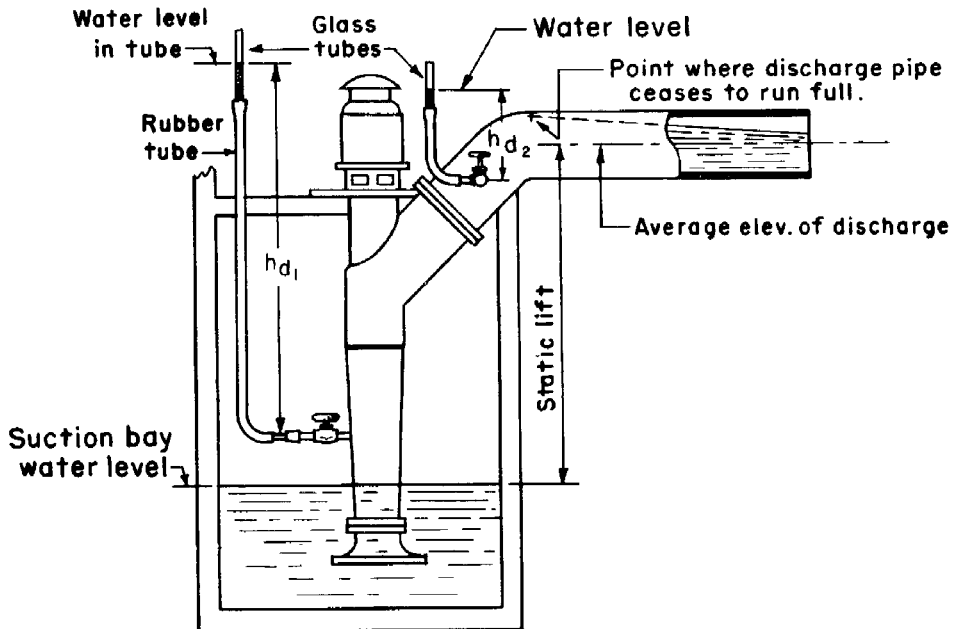
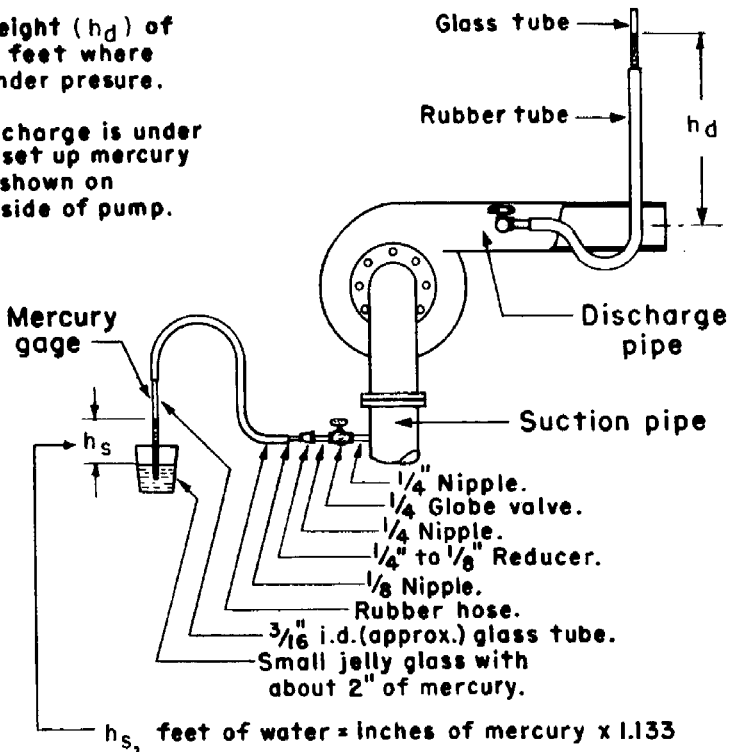

REFERENCE
U. S. D. A. Technical Bulletin
No. 1008

U. S. DEPARTMENT OF AGRICULTURE
SOIL CONSERVATION SERVICE
ENGINEERING DIVISION - DRAINAGE SECTION

STANDARD DWG. NO.
ES - 731
SHEET 1 Of 1
DATE February 1971

Figure 7-17, Suction and discharge gages for pumping plant field tests

1. Drill vertical hole through discharge pipe at point selected. The hole should be drilled and threaded so that the stuffing box of the pitot tube may be screwed in. (See figure 7-18.)
2. Assemble and center the pitot tube in the pipe by measuring up from the bottom of the pipe. The stuffing box usually projects slightly into the pipe at the upper side and this prevents centering the pitot tube by measuring from the top of the pipe. Drill a hole in a 1- by 6-inch board as shown in figure 7-18 so that the point of the pitot tube is at the center of the pipe when the centerline hole of the board supports the handle.
3. Drill five additional holes above the centerline hole at distances as follows:
 - a. 0.949 r
 - b. 0.837 r
 - c. 0.707 r
 - d. 0.548 r
 - e. 0.316 r

Establish a similar set of holes below the centerline. These holes are set so that 5 and 6 are on the circumference of 0.1 the pipe area. Points 4 and 7 are on the circumference of 0.3 the area. Points 3 and 8, 0.5 area; 2 and 9, 0.7 area; and 1 and 10, 0.9 area.

4. Raise water from discharge pipe so that upper and lower water levels may be read on the gage. This is accomplished by a valve at the end of the pitot tube gage. A vacuum pump is required to draw water into the glass tubes if pipe is under vacuum.
5. Starting at top of pipe take velocity head readings at holes 1 to 10, inclusive, moving the pitot tube down the pipe. Take a second reading from each hole, starting at the bottom and moving the tube up.
6. Centerline readings are made but are not averaged in.
7. Compute average velocity in pipe by averaging all velocity head readings except the center reading and substitute in the formula

$$v = \sqrt{2gh}$$

Pump efficiency

Pump efficiency is computed by the following formula

$$e = \frac{\text{GPM} \times H_t}{\text{BHP} \times 3960}$$

where

- e = pump efficiency
 GPM = gallons per minute
 H_t = total head on pump
 BHP = brake horsepower input into pump shaft

TULANE PITOT TUBE AND TEMPLATE FOR MEASURING WATER VELOCITY IN PIPES

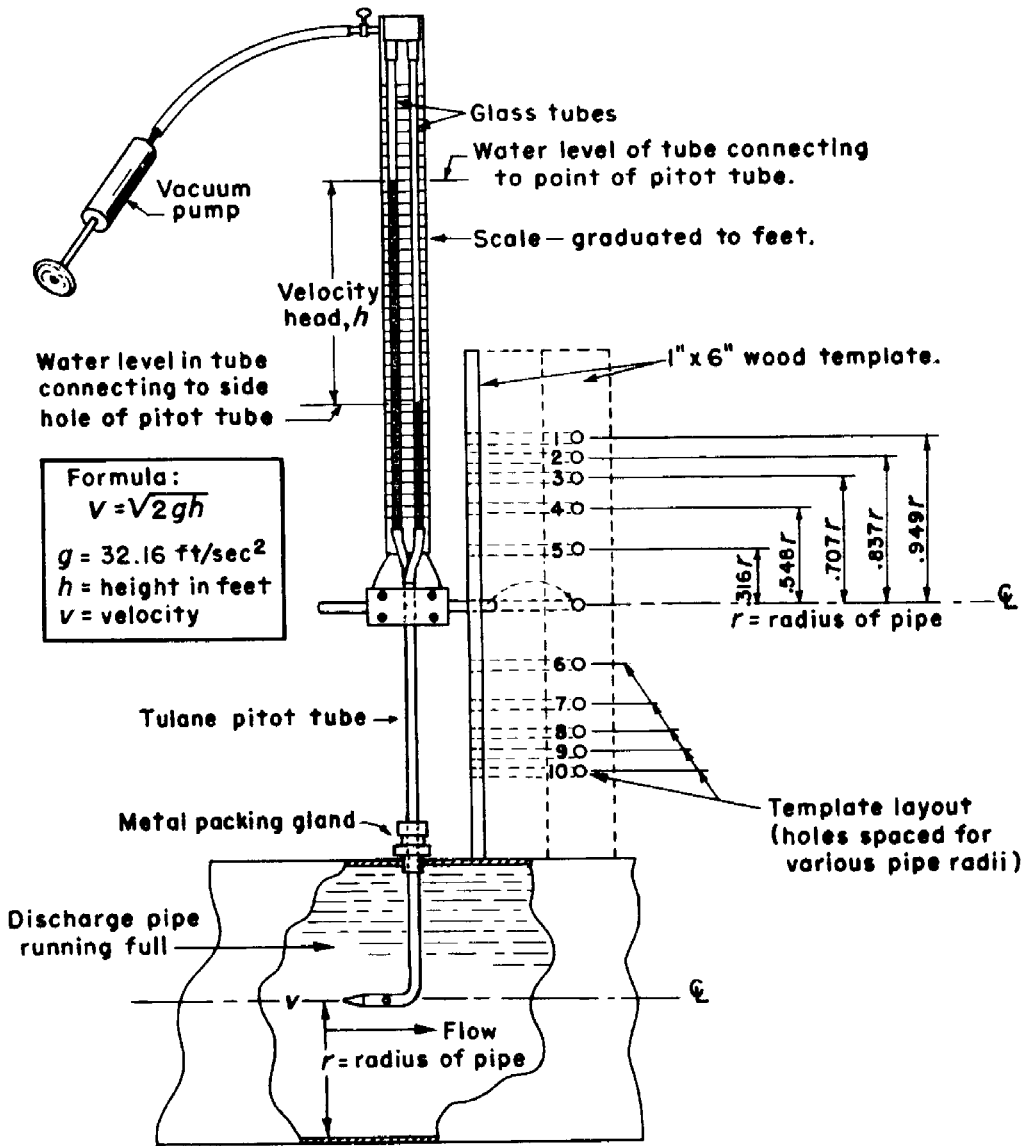

Formula:

$$v = \sqrt{2gh}$$
 $g = 32.16 \text{ ft/sec}^2$
 $h = \text{height in feet}$
 $v = \text{velocity}$

REFERENCE
 U. S. D. A. Technical Bulletin
 No. 1008

U. S. DEPARTMENT OF AGRICULTURE
 SOIL CONSERVATION SERVICE
 ENGINEERING DIVISION - DRAINAGE SECTION

STANDARD DWG. NO.
 ES - **732**
 SHEET 1 OF 1
 DATE February 1971

Figure 7-18, Tulane pitot tube and template for measuring water velocity in pipes

Operation and Maintenance

Operation and maintenance of a drainage pumping facility is more often in the hands of untrained people. Therefore, equipment should be as reliable, simple in construction and operation, and require the least amount of maintenance as can be obtained economically. Likewise, simple and explicit instructions on operation and maintenance should be made available to those responsible.

Operators should know the instructions on pumps, motors, engines, and control devices and should follow the best operating procedures. Pumps depending upon water lubrication should not operate empty. Where pumps depend upon priming, complete filling of water should be accomplished so pockets of air will not collect in the casing around the shaft and thus reduce discharge. Where prime movers are used such as engines that permit substantial variation in speed, pump operation should be regulated to provide the most efficient speed as determined from tests or characteristic curves. Where several units are included in the facility, the most efficient unit or combination of units should be used for most of the pumping. Each unit should be operated periodically to assure reliable operation when needed. Equipment should be kept in good repair. Equipment, plant, and grounds should be kept clean and orderly to minimize the hazard of fire, assure ready access and efficient operation and prevent accidents.

Thorough inspection of the facility should be made periodically during operation, at least monthly during periods of nonoperation, and just prior to the expected time of continuous or peak usage. Inspection; cleanup and oiling of engines, motors and pumps; flushing of sumps; and replenishing of fuel and lubricants should follow immediately after a major operation in readiness for the next period of use.

Occasional tests are desirable, particularly on the larger facilities, in order to detect poor operating efficiency as may result from wear and other less obvious causes that indicate need for such timely repairs as replacement of worn impellers, etc.

Inspections should indicate the condition of the plant forebay and discharge bay areas, and arrangements should be made for disposal of debris, drift, and trash accumulations that would interfere with gate operation and trash racks. The inspection should disclose any erosion, leaks, and displacement of riprap protection at foundations that should be repaired. At least seasonally, hinges and seats of flap gates and slide controls of valve gates should be lubricated and trial operated. Also, stop logs and other emergency equipment should be checked for adequacy.

Monthly inspections should include test runs of pumps and power equipment. Power units such as the gasoline engine should be operated to check battery units and prevent accumulation of condensation and sludge in fuel lines and carburetors. Automatic controls, particularly the solenoid type, are quite susceptible to deterioration after periods of disuse and should be checked regularly. These checks on their condition are important since workmen skilled in their repair and maintenance are not always readily available at times of emergency.

An operations and maintenance manual should be prepared which will include repair manuals, shop drawings, wiring diagrams, plumbing diagrams, periodic (as monthly) inspection sheets, directions for operation and "troubleshooting."

The manual should contain methods for testing operation of pumps, controls, and safety switches.

Accurate operation and cost records are necessary for adequate supervision and economical operation of a pumping plant. Preventive maintenance, proven least expensive in construction and industry, requires adequate records and maintenance schedules.

References

- (1) HYDRAULIC INSTITUTE STANDARDS, 12th Edition
1969. Hydraulic Institute, New York, N.Y.
- (2) UNITED STATES DEPARTMENT OF AGRICULTURE, SOIL CONSERVATION SERVICE
1971. National Engineering Handbook, Section 4, Hydrology.
- (3) SUTTON, JOHN G.
1950. Design and Operation of Drainage Pumping Plants, U.S. Dept. Agr.,
Soil Conservation Service Technical Bulletin 1008, U.S.
Government Printing Office.
- (4) UNITED STATES DEPARTMENT OF COMMERCE
1961. Weather Bureau Technical Paper 40, U.S. Government Printing
Office.
- (5) UNITED STATES DEPARTMENT OF COMMERCE
1964. Weather Bureau Technical Paper 49, U.S. Government Printing
Office.
- (6) ADAMS, H. W.
1957. Pumping Requirements for Levied Agricultural Areas, ASCE
Journal of Irrigation and Drainage Division, Vol. 83,
No. 1R1, New York, N.Y.
- (7) UNITED STATES DEPARTMENT OF AGRICULTURE, SOIL CONSERVATION SERVICE
1959. National Engineering Handbook, Section 15, Irrigation,
Chapter 8.
- (8) UNITED STATES DEPARTMENT OF AGRICULTURE, SOIL CONSERVATION SERVICE
1951. National Engineering Handbook, Section 5, Hydraulics.
- (9) KING, H. W. and BRATER, E. F.
1963. Handbook of Hydraulics, 5th Edition, McGraw Hill, New York, N.Y.
- (10) W. Q. O'NEALL CO.
1936. Handbook of Water Control, Chicago, Illinois.
- (11) LARSON, C. L. and MANBECK, D. M.
1961. Factors in Drainage Pumping Efficiency, Agr. Eng. Vol. 42.
American Society of Agricultural Engineers, St. Joseph, Michigan.

APPENDIX A

Determining Pumping Plant Capacity Based on Hydrologic and Economic FactorsExample

A watershed project is proposed for the Upper Maple River in Gratiot, Clinton, and Shiawassee Counties, Michigan to provide flood protection and improved drainage necessary for the production of navy bean and sugar beet crops. Engineering studies* show (a) that water retarding structures will provide only a minor part of the needed flood protection, (b) that extensive diking and channel improvements are necessary, and (c) that several low laying areas behind dikes must be pumped at high river stages in order to avoid extensive (economically infeasible) channel enlargement and deepening downstream. One of the pumped areas would be located within Hamilton and Elba Townships in Gratiot County. (See figure 7A-1.) The dikes (extending along the east bank of Bear Creek from a reach west of the town of Ashley to a gated outlet into the Maple River and thence along the north bank of Maple River to a reach west of the town of Bannister) would enclose 24 square miles of land that at high flows in Maple River would be drained by pumps. The pumps are to be located near the junction of Bear Creek and Maple River. The pumping rate is to be determined within an acceptable cost-benefit ratio on the basis of an evaluation of various pumping rates and their effect upon the flooding and drainage impairment of the area.**

Rainfall determination

Soil conditions and land use under project objectives are estimated. Amounts of rainfall for various frequencies of occurrence ranging from 3 hours to 10 days' duration are obtained from U.S. Weather Bureau Publications TP 40 (4) and TP 49 (5). Values are plotted as shown in figure 7A-2.

Runoff determination

The amounts of runoff for various durations and frequencies of occurrence are determined as shown in table 7A-1. These values are obtained from figure 7A-2, soil cover complex number 77 selected from table 9.1 NEH Section 4 - Hydrology, and Standard Drawing ES 1001 (figure 10.1 NEH section 4 - Hydrology)

Watershed hydrograph bases (Chapter 16 - NEH Section 4 - Hydrology) are determined using a computed time of concentration (T_c) of 7.23 hours. The time of hydrograph peak (T_p) is based on equation

$$T_p = \frac{D}{2} + 0.6 T_c$$

where D is the storm duration and the time of hydrograph base (T_b) is determined from the equation

$$T_b = 2.67 T_p$$

* SCS Watershed Work Plan Investigations by Huson A. Amsterberg and Russel H. Bauerle, Hydraulic Engineers, and John L. Okay, Agricultural Economist.

** Pumping for Agricultural Areas by Guy B. Fasken, SCS, Lincoln, Nebraska, and Pumping Requirements for Levied Agricultural Areas by H. W. Adams (6).

PROJECT LOCATION MAP
UPPER MAPLE RIVER WATERSHED

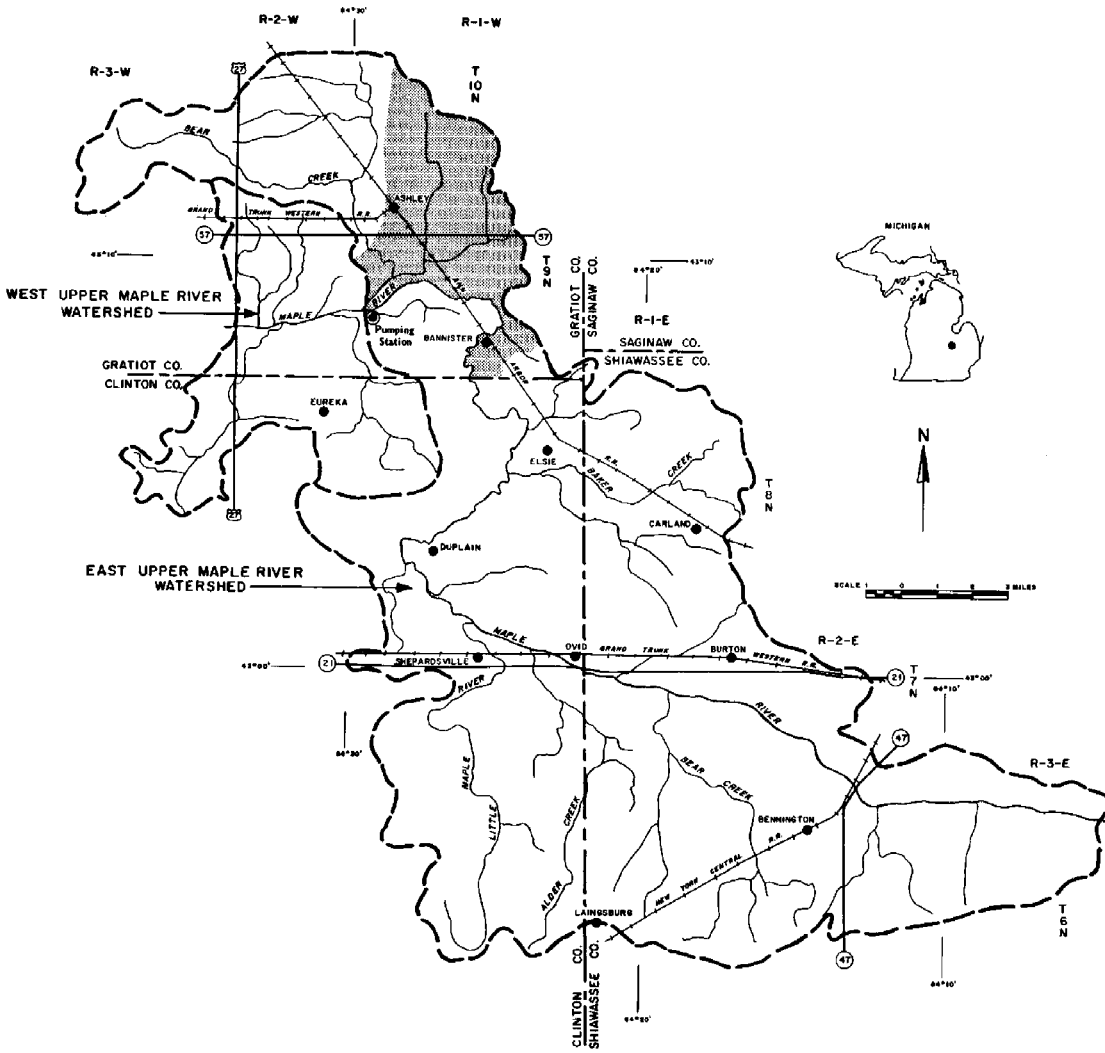

Figure 7A-1, Pumping plant location

Table 7A-1, Rainfall - runoff duration - frequency

Rainfall Duration Days	1-Year Frequency Inches		2-Year Frequency Inches		5-Year Frequency Inches		10-Year Frequency Inches		25-Year Frequency Inches	
	Rainfall	Runoff	Rainfall	Runoff	Rainfall	Runoff	Rainfall	Runoff	Rainfall	Runoff
0.125	1.30	0.14	1.57	0.25	1.97	0.43	2.28	0.61	2.57	0.78
0.250	1.54	0.24	1.78	0.33	2.28	0.61	2.62	0.82	2.97	0.98
0.500	1.77	0.33	2.05	0.48	2.65	0.83	3.05	1.11	3.42	1.37
1.000	2.09	0.50	2.40	0.68	3.04	1.10	3.50	1.43	3.95	1.77
2.000	2.43	0.70	2.75	0.89	3.46	1.41	4.00	1.81	4.50	2.21
4.000	2.84	0.96	3.20	1.21	4.00	1.81	4.60	2.29	5.20	2.79
7.000	3.21	1.22	3.56	1.47	4.50	2.21	5.20	2.79	5.80	3.30
10.000	3.48	1.41	3.88	1.71	4.80	2.45	5.60	3.13	6.30	3.74

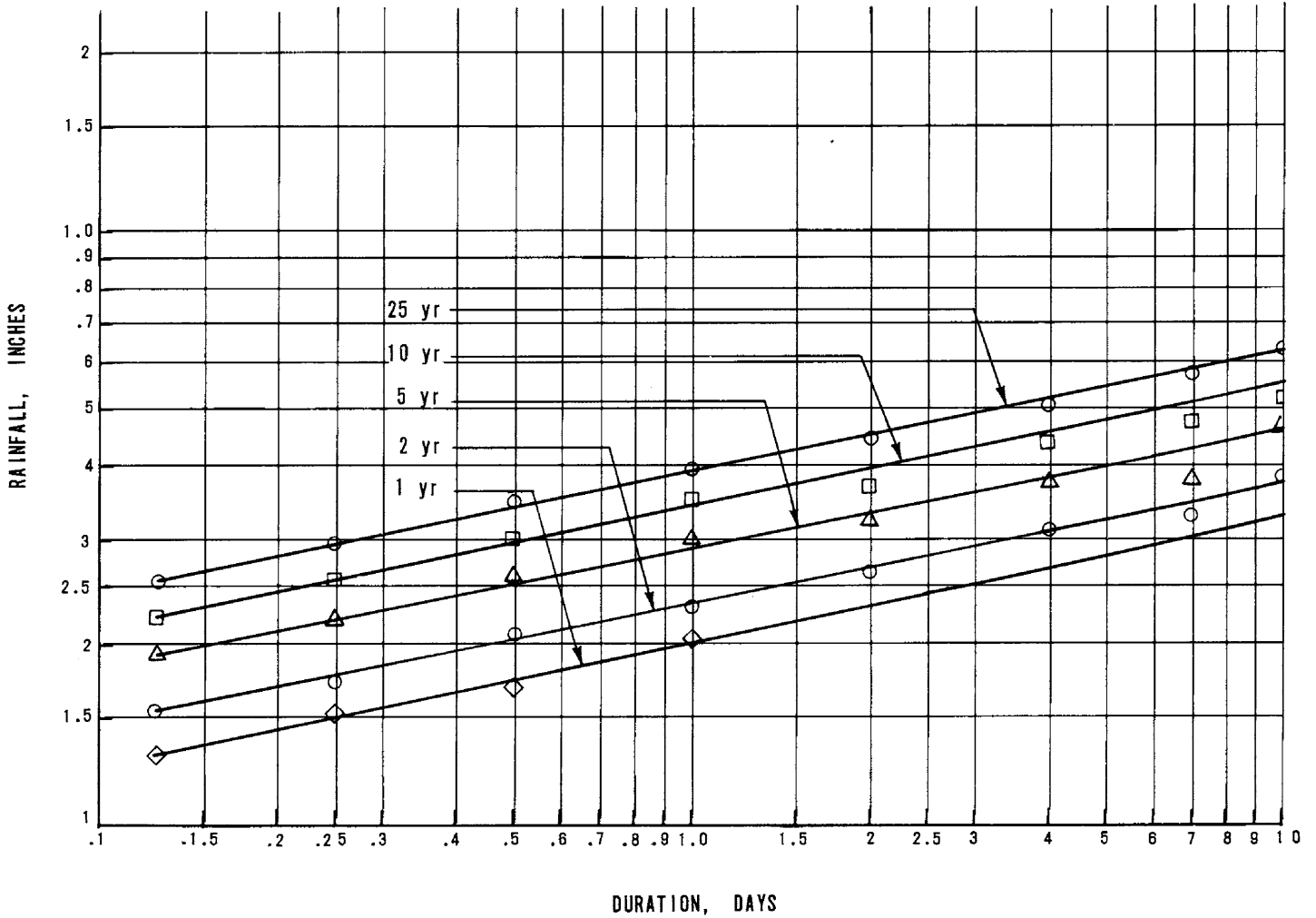

Figure 7A-2, Rainfall duration-frequency

The computed hydrograph base values are shown in table 7A-2.

Table 7A-2, Hydrograph base time length

Duration, Days	Hydrograph Base Time T_b , Days
0.125	0.65
0.250	0.81
0.500	1.15
1.000	1.82
2.000	3.16
4.000	5.82
7.000	9.84
10.000	13.85

Mass runoff curves are prepared as shown in figure 7A-3 by plotting accumulated runoff for the various durations and frequencies against time of the hydrograph bases.

Runoff, pumping rate, storage relationships

By plotting pumping rates against time of the hydrograph base as shown in figure 7A-3, the maximum storage for each pumping rate and frequency can be determined by measurement of the maximum increment between the pumping rate line and the mass runoff curve. This is done by drawing a line representing the pumping rate tangent to the mass runoff line. Where this line intercepts the runoff on the vertical axis, the maximum required storage for the given frequency and pumping rate is indicated. These storage values are shown in table 7A-3 and are plotted against percent chance of occurrence for each pumping rate as shown in figure 7A-4.

Table 7A-3, Required maximum storage, inches

Pumping Rate Inches/Day	Frequency				
	1-Year	2-Year	5-Year	10-Year	25-Year
0	1.42	1.72	2.46	3.13	3.75
0.1	0.41	0.64	1.27	1.83	2.40
0.2	0.12	0.30	0.76	1.17	1.62
0.3	0	0.14	0.53	0.89	1.27
0.5		0	0.25	0.54	0.83
0.7			0	0.30	0.53
1.0				0	0.17
1.5					0

The area under each curve, determined by planimeter measurement, gives the average annual storage requirement for each pumping rate as shown in table 7A-4 and from which the curve shown in figure 7A-5 is developed.

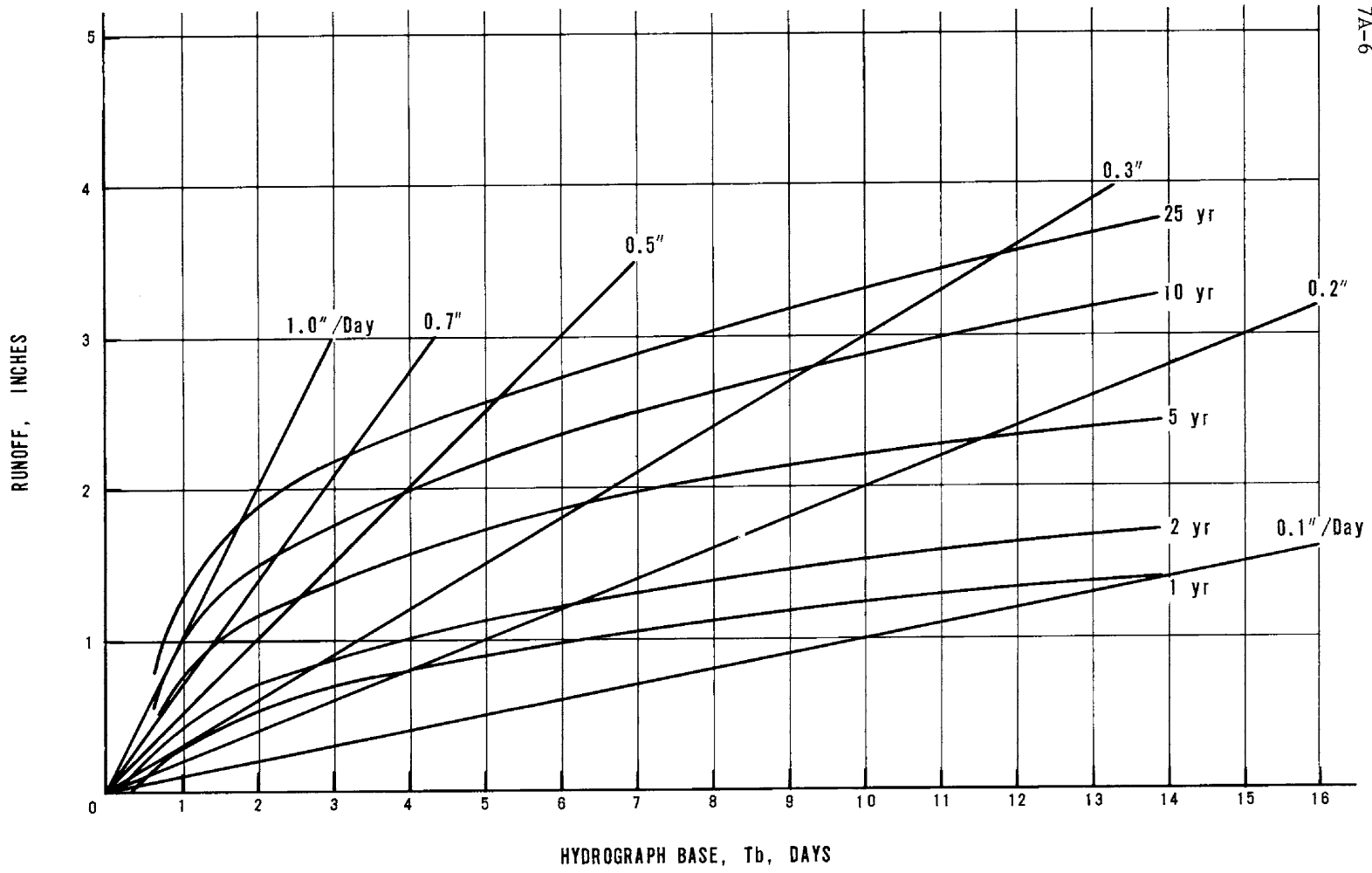

Figure 7A-3, Mass runoff, frequency, duration, and pumping rate relationships

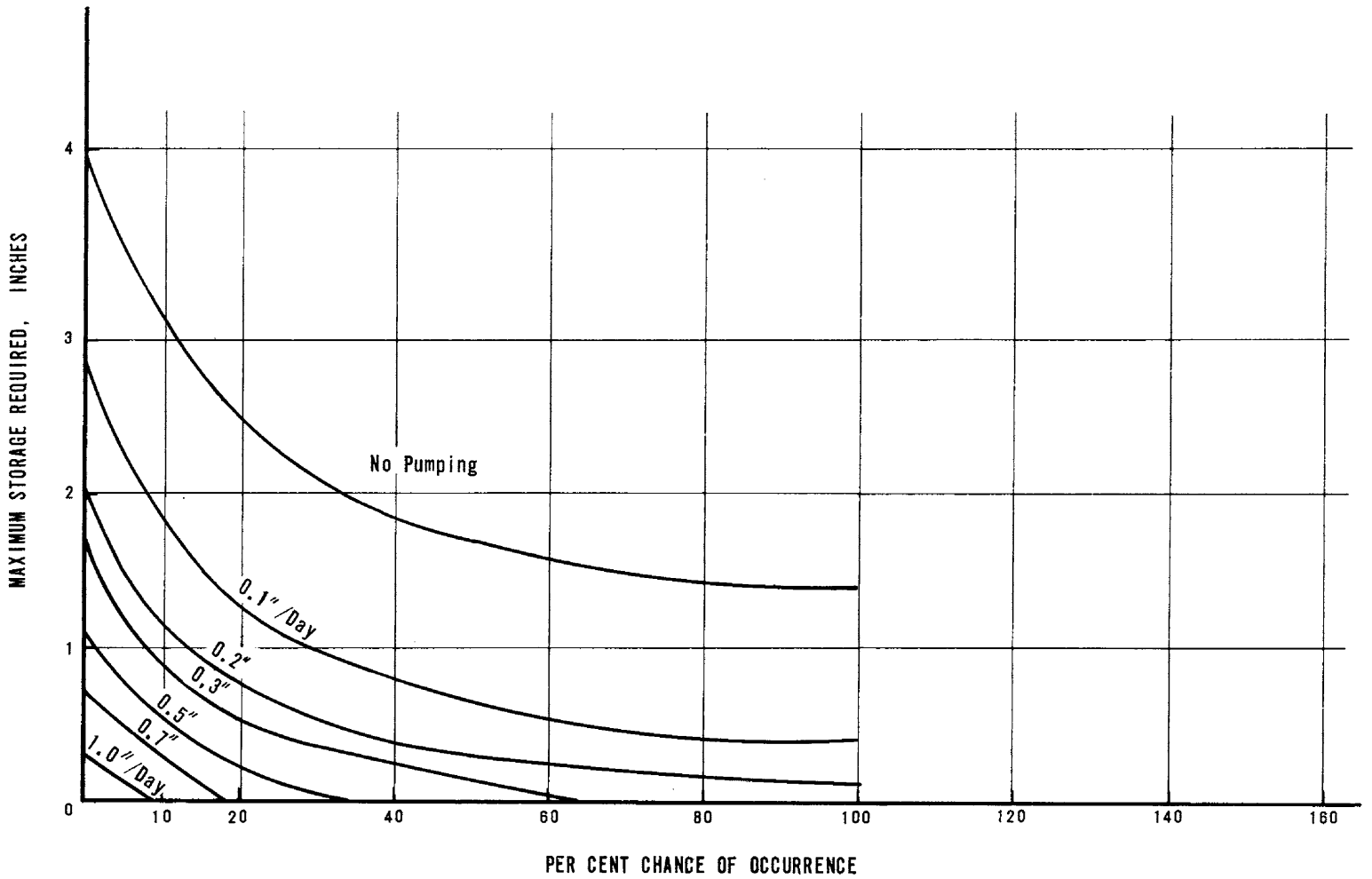

Figure 7A-4, Maximum required storage for various chances of occurrence and pumping rates

Table 7A-4, Average annual storage for various pumping rates

Pumping Rate Inches/Day	Area Under Curve, Sq.In.	Value Per Unit	Average Annual Storage, Inches
0	10.09	1 x .2 = 0.2	2.02
0.1	4.48	1 x .2 = 0.2	0.90
0.2	2.45	1 x .2 = 0.2	0.49
0.3	1.46	1 x .2 = 0.2	0.29
0.5	0.68	1 x .2 = 0.2	0.14
0.7	0.35	1 x .2 = 0.2	0.07
1.0	0.08	1 x .2 = 0.2	0.02

Stage-storage relationships

A topographic survey of the area is made from which a topographic map is prepared for determining the stage-storage relationships. Two-foot contour intervals (preferably 1-foot) are established from which mapped surface areas at the several elevations are measured by planimeter. Stage, area, storage relationships are then determined as tabulated in table 7A-5.

Table 7A-5, Stage, area, storage relationships

Elev. MSL	Stage Feet	Total Area Acres	Cultivated Area - Acres	Storage Acre Feet	Cumulative Storage Acre Feet	Cumulative Storage Inches
651	0	0	0	0	0	0
652	1	10	0	5	5	0.004
653	2	29	0	20	25	0.020
654	3	62	0	46	71	0.060
655	4	229	0	146	217	0.170
656	5	1100	784	665	882	0.690
657	6	1536	1176	1318	2200	1.720
658	7	2010	1603	1773	3973	3.110
659	8	2545		2278	6251	4.890
660	9	2997				

Stage, damage area, benefit area relationships

Information in table 7A-5 is used to establish relationships between stage and the areas of flooding and areas of impaired drainage.

Area flooded is the total surface area at each elevation. Impaired drainage is determined on the basis of normal depth of tile below the surface (3 feet in Michigan) plus an added foot to allow for the tile slope toward the outlet. Drainage impairment is considered as occurring when the resulting elevation of tile is submerged. When the pump storage area is flooded to a specified elevation, the area at an elevation of 4 feet above the specified elevation, less the flood area at the specified elevation, then becomes the area of drainage impairment. Table 7A-6 gives these values. Relationships of elevation to storage, cultivated and flooded, and area of impaired drainage can then be determined as shown in figure 7A-6.

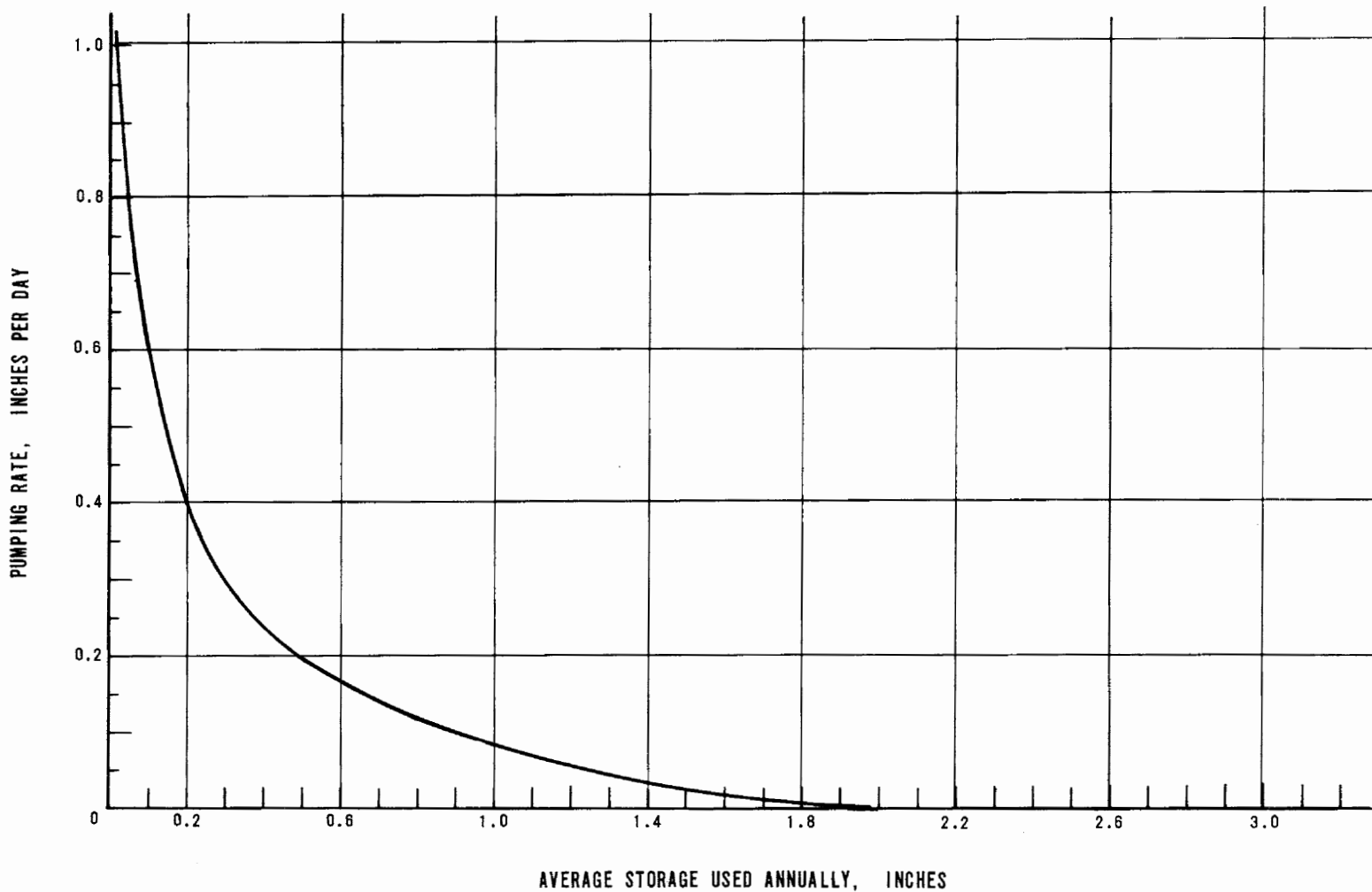

Figure 7A-5, Average annual storage at various pumping rates

Table 7A-6, Relationships - stage to impaired drainage area

Elevation MSL	Surface Acres	Flooded Acres	Total Affected Acres	Impaired Drainage Acres
651	0	0	0	0
652	10	10	1,100	1,090
653	29	29	1,536	1,507
654	62	62	2,010	1,948
655	229	229	2,545	2,316
656	1,100	1,100	2,997	1,897
657	1,536	1,536	3,560	2,024
658	2,010	2,010	4,120	2,110
659	2,545	2,545	4,685	2,140
660	2,997			
661	3,560			
662	4,120			
663	4,685			

Pumping rate, storage, and damage area relationships

From the established relationships of pumping rates, annual storage, storage elevations, and related area flooded, the area of benefit is determined. These relationships and their sources are shown in table 7A-7.

Table 7A-7, Relationships - stage, storage, pumping rate, and affected acres

Pumping Rate Inches/Day	Average Annual Storage Used Inches Fig. 7A-4	Related Sump Elevation MSL Fig. 7A-5	Average Annual Area Flooded Acres Fig. 7A-5	Average Annual Area Benefited by Reduced Flooding Acres
0.00	2.02	657.25	1290	0
0.10	0.90	656.25	875	415
0.20	0.49	655.70	570	720
0.25	0.39	655.50	405	885
0.30	0.32	655.37	285	1005
0.35	0.25	655.20	160	1130
0.40	0.20	655.08	70	1220
0.45	0.16	654.90	0	1290
0.50	0.14	654.80	0	1290
0.60	0.09	654.30	0	1290
0.70	0.07	654.10	0	1290
0.80	0.04	653.60	0	1290
0.90	0.03	653.20	0	1290
1.00	0.02	652.80	0	1290

Value of damages and benefits

Flood damages occur through reduction in yields, increased production costs, and reduction in crop quality. From an economic study (based on a complex economic model evaluating such factors not explained herein), an average annual flood damage of \$22.57 per cultivated acre has been determined. This value also represents the benefits accruing to each acre for which flooding

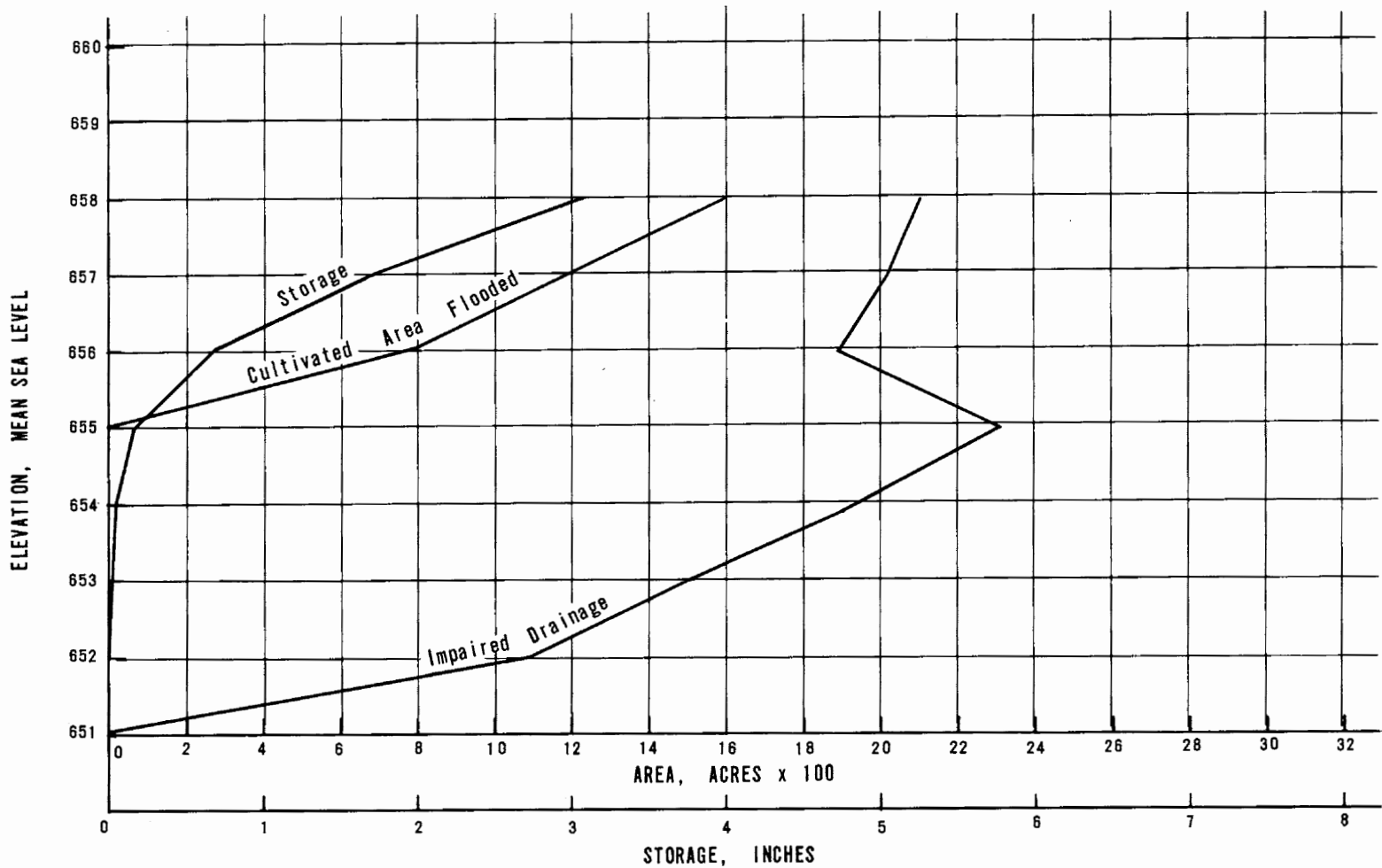

Figure 7A-6, Relationships of stage, storage, and affected areas

is prevented. Applying this value to the acres benefited, the average annual flood damage reduction for each pumping rate is determined as shown in table 7A-8.

Table 7A-8, Relationships - pumping rate to benefits

Pumping Rate Inches/Day	Area Benefited Annually-Acres	Benefits Dollars/Acres	Annual Benefits Dollars
0	0	22.57	0
0.10	415	22.57	9,367
0.20	720	22.57	16,250
0.25	885	22.57	19,974
0.30	1,005	22.57	22,683
0.35	1,130	22.57	25,504
0.40	1,220	22.57	27,535
0.45	1,290	22.57	29,115
0.50	1,290	22.57	29,115
0.60	1,290	22.57	29,115
0.70	1,290	22.57	29,115
0.80	1,290	22.57	29,115
0.90	1,290	22.57	29,115
1.00	1,290	22.57	29,115

The effect of impaired drainage is evaluated. Plotted mass curves and pumping rates of figure 7A-3 are used to determine the storage required each day for various frequencies and pumping rates. Table 7A-9 shows the data for no pumping and for a pumping rate of one-half inch per day. Other pumping rates are evaluated (not shown herein). Figure 7A-6 is used to convert storage to acres of impaired drainage. Information for duration of impaired drainage at a pumping rate of one-half inch per day is shown in figure 7A-7.

From a crop budgetary model (not explained herein), the average annual damage from impaired drainage caused by reduced yields, increased production cost, and reduced crop quality is determined to be \$14.85 per cultivated acre. This also represents the net benefit obtained by drainage, allowing for the on-farm cost of drainage improvement.

It is assumed that drainage impairment for 3 days or less causes no measurable crop damage, that impairment during the growing season for 21 days or more causes damage equal to that on land without installed drains, and that a linear relationship exists between damage value and duration of impairment. Thus average damage per day of duration can be taken to be \$0.825.

From plottings of acres of impaired drainage and days duration for the various frequencies and pumping rates, the acre days of impaired drainage exceeding 3 days duration are measured. Since damage of impaired drainage is for more than 3 and less than 21 days, the acre days for no pumping are 18 times the acres effected. This information is shown in table 7A-10. Damage for various pumping rates and frequencies is then determined on the basis of \$0.825 per acre day. Total damages are determined by plotting damages against percent chance of occurrence and measuring the area under the curve as shown in figures 7A-8 and 7A-9 for no pumping and for pumping one-half inch a day, respectively. Other rates are measured next and then tabulated as shown in table 7A-11. This table shows flood and impaired drainage damages and corresponding weighted benefits by seasonal storm distribution. Total average annual benefits are plotted as shown in figure 7A-10.

Table 7A-9, Relationships - impaired drainage and storage for various frequencies and pumping rates

Pumping Rate	Time After Runoff Begins Days	1-Year Frequency		2-Year Frequency		5-Year Frequency		10-Year Frequency		25-Year Frequency	
		Storage Required Inches	Impaired Drainage Acres	Inches	Acres	Inches	Acres	Inches	Acres	Inches	Acres
No Pumping	Maximum	1.41	1,990	1.71	2,025	2.45	2,070	3.13	2,110	3.74	2,120
0.5 In./Day	1	0	-	0	-	0.24	2,210	0.50	2,020	0.72	1,900
	2					0.15	2,215	0.49	2,020	0.83	1,920
	3					0	-	0.28	2,180	0.65	1,920
	4							0	-	0.42	2,080
	5									0.12	2,110

IMPAIRED DRAINAGE, ACRES x 100

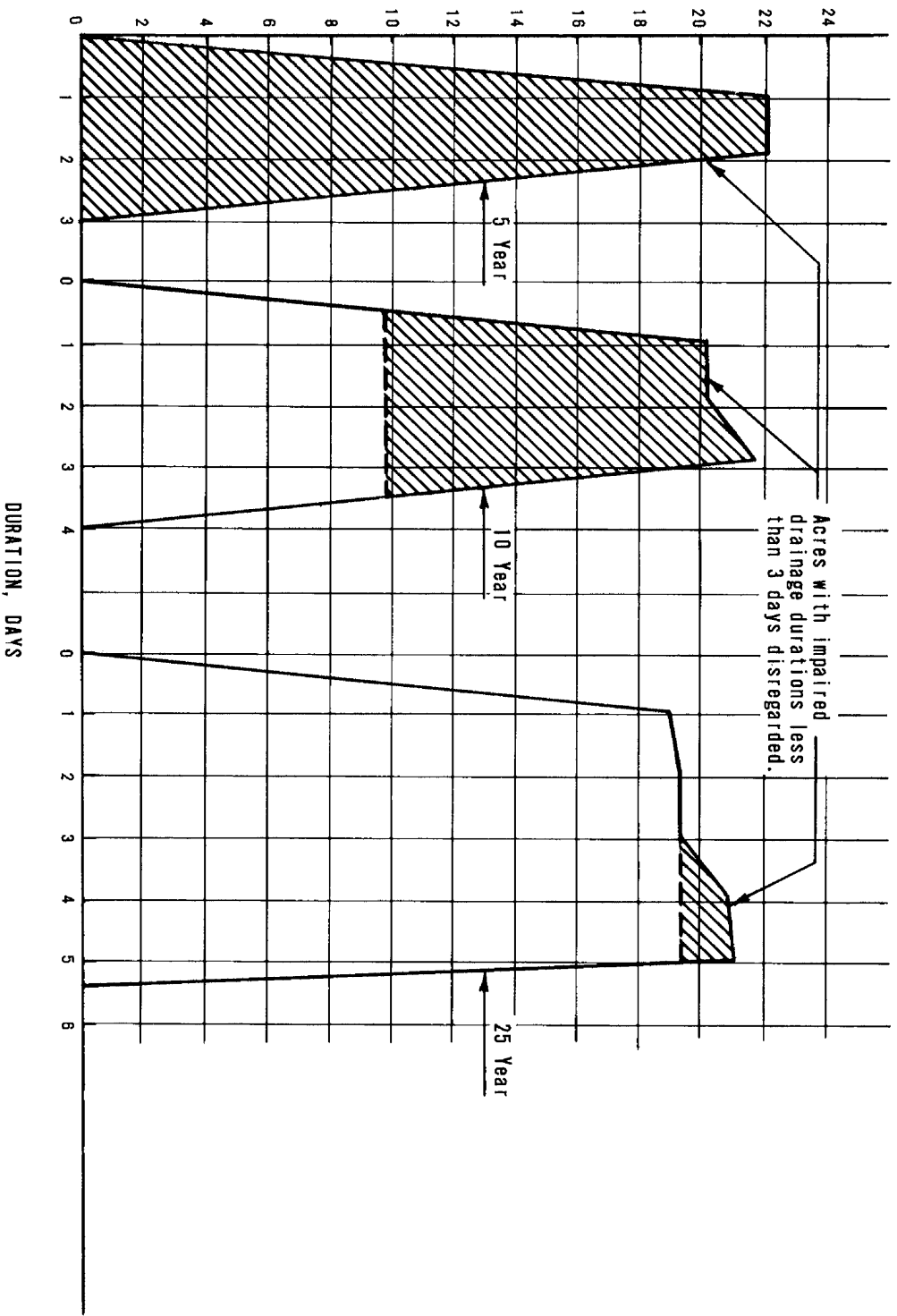

Figure 7A-7, Acre-days impaired drainage at 1/2 inch pumping rate for various frequencies

Table 7A-10, Damages for various pumping rates and frequencies of occurrence

Pumping Rate Inch/Day	Frequency of Occurrence Year	Area Under Curve Sq.In.	Value per Unit	Impaired Drainage Acre-Day	Damages \$0.825 Per Acre-Day	Total Damage Dollars
0.6	1	0	400 x 2	0	0.825	0
	2	0	= 800	0		0
	5	0		0		0
	10	0		0		0
	25	4.55		3,640		3,000
0.5	1	0	400 x 2	0		0
	2	0	= 800	0		0
	5	0		0		0
	10	4.24		3,392		2,800
	25	11.21		8,975		7,400
0.45	1	0	400 x 2	0		0
	2	0	= 800	0		0
	5	0.60		480		396
	10	9.35		7,480		6,175
	25	13.45		10,560		8,720
0.4	1	0	400 x 2	0		0
	2	0	= 800	0		0
	5	4.30		3,440		2,840
	10	12.70		9,650		7,960
	25	16.99		13,600		11,220
0.3	1	0	400 x 2	0		0
	2	0	= 800	0		0
	5	14.80		11,840		9,770
	10	19.62		15,700		12,950
	25	26.89		21,500		17,730
0	1		400 x 2	35,820		29,550
	2		= 800	36,450		30,100
	5			37,260		30,700
	10			37,980		31,350
	25			38,160		31,500

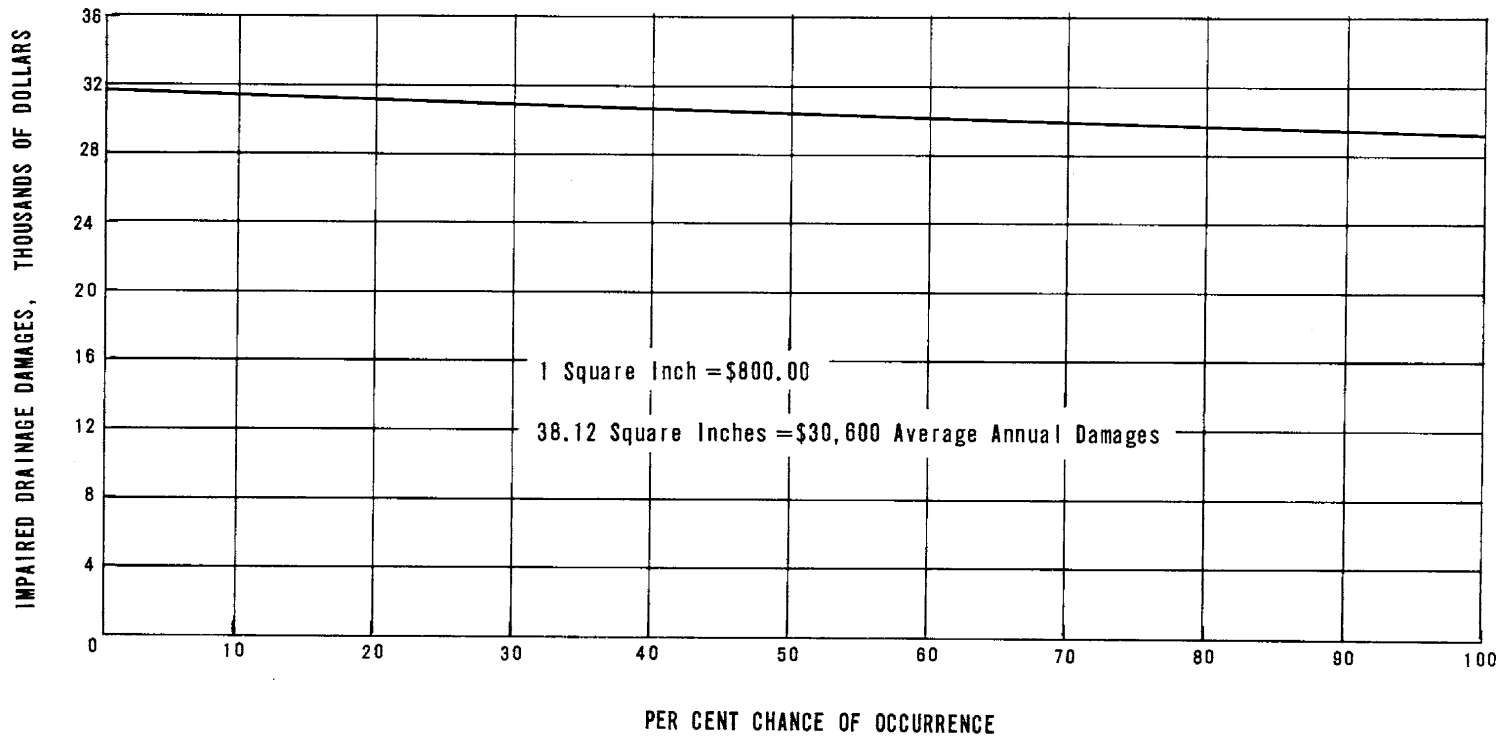

Figure 7A-8, Impaired drainage damages with no pumping

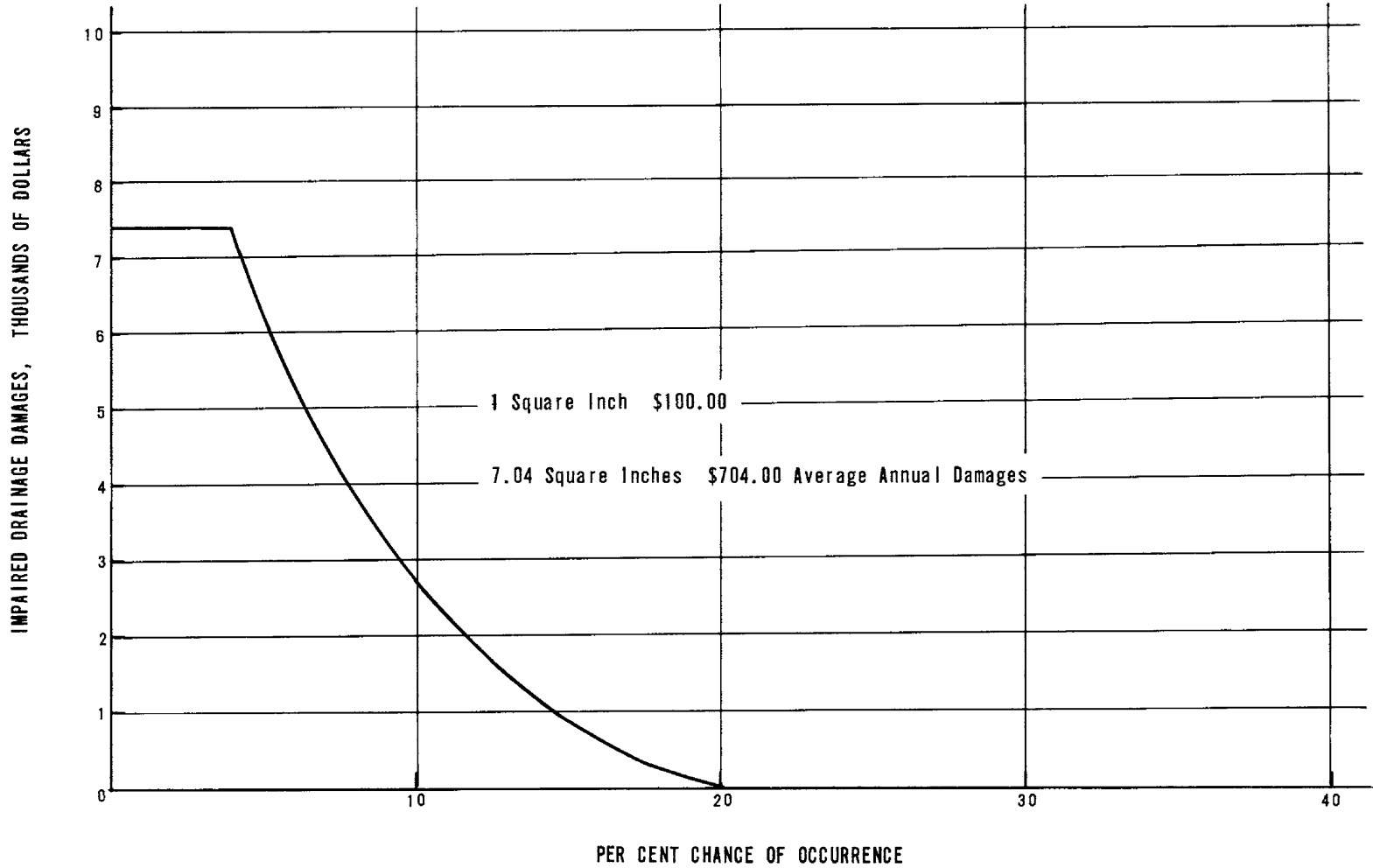

Figure 7A-9, Value of damage by impaired drainage at 1/2 inch per day pumping rate

Table 7A-11, Average annual damages and benefits for various pumping rates

Pumping Rate Inches/ Day	Area Flooded				Area With Impaired Drainage		
	Average Annual Area Flooded Cult A	Average Annual Area Benefited Cult A	Damages @ 22.57 Per Cult A Dollars	Benefits Per Cult A Dollars	Average Annual Damages Dollars	Average Annual Benefits Dollars	Weighted Average Annual Benefits ^{1/} Dollars
0	1290	0	29,115	0	30,600	0	0
0.1	875	415	<u>2/</u>	<u>2/</u>	<u>2/</u>	<u>2/</u>	<u>2/</u>
0.2	570	720	<u>2/</u>	<u>2/</u>	<u>2/</u>	<u>2/</u>	<u>2/</u>
0.3	285	1005	6,432	22,683	4,444	26,156	18,126
0.4	70	1220	1,580	27,535	1,906	28,694	19,885
0.5	0	1290	0	29,115	704	29,896	20,718
0.6	0	1290	0	29,115	200	30,400	21,067

^{1/} Weighted by 63.9 percent of excessive storms which occur during the growing season (April through November).

^{2/} Not evaluated because pumping rates less than 0.3 inch per day are usually considered inadequate.

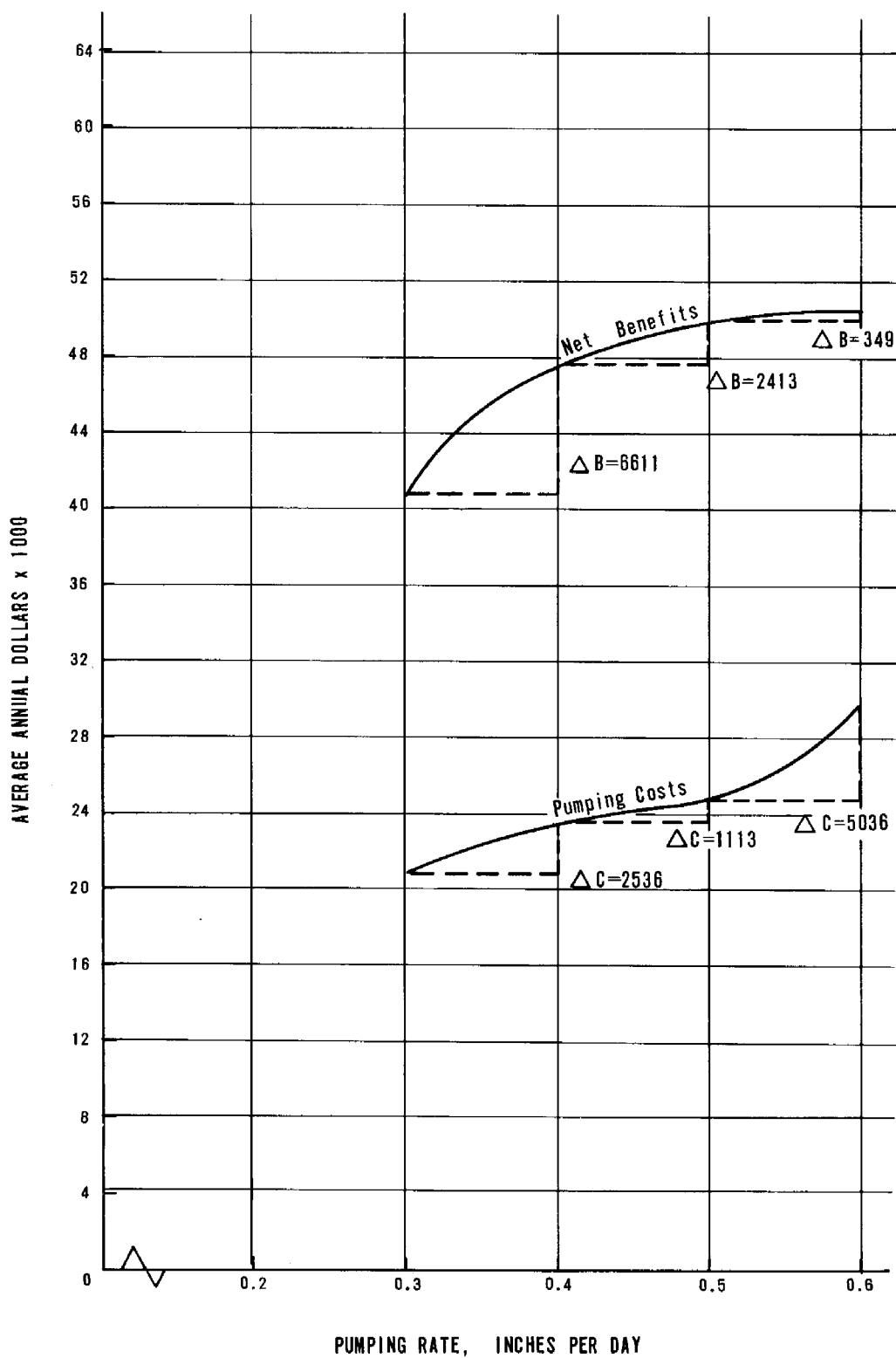

Figure 7A-10, Cost-benefit relationship at various pumping rates

Operating costs

To optimize benefits a relationship is needed between pumping rates and total costs. Costs fall into two categories. The first includes cost of the pumping plant installation, including the sump and housing, the pumps, power units, land rights, engineering, and installation. The second includes the cost of power, operation, maintenance, and equipment replacement.

Since gravity outlet will be obtained at low river flows, percent of total runoff pumped is determined as follows: The main channel discharge at which pumping must begin is computed in cubic feet per second and cubic feet per second per square mile. Since discharge records for Maple River watershed were not available, the cubic feet per second per square mile rate is applied as a base determined from the Red Cedar River at East Lansing, which is a nearby gaged watershed of similar size and characteristics. Dates when the discharge exceeded the estimated base flow are tabulated for 9 years of record. Deer Creek, a small gaged watershed within the Red River watershed, draining an area of 16.3 square miles, is used to determine the volume of runoff occurring when the Red Cedar was above base flow. The percent runoff above the base, as compared to total runoff, is then applied to the Maple River runoff to determine the volume of runoff that must be pumped. These data also provide a seasonal distribution for pumping by months, used in determining operating costs.

Installation costs and equipment replacement costs are amortized and added to annual operating costs to obtain a total average annual cost. These data are listed in table 7A-12 and plotted in figure 7A-10.

Table 7A-12, Cost-benefits at various pumping rates

Pumping Rate Inches/Day	Total Average Annual Damages <u>1/</u> Dollars	Total Average Annual Benefits Dollars	Total Average Annual Pump Costs Dollars
0	46,713	0	0
0.1	<u>2/</u>	<u>2/</u>	<u>2/</u>
0.2	<u>2/</u>	<u>2/</u>	<u>2/</u>
0.3	8,988	40,809	20,915
0.4	2,676	47,420	23,451
0.5	405	49,833	24,564
0.6	115	50,182	29,600

1/ Flood damages plus weighted drainage damages from table 7A-11.

2/ Not evaluated because pumping rates less than 0.3 inch per day are usually considered inadequate

Pumping rate at optimum cost-benefit ratio

Optimization criteria are based on an equimarginal principle in which additional units of input are added until cost of the last unit of input equals the value of the unit so produced. Thus optimum pumping rate occurs when an incremental increase in the pumping rate just equals the added benefits derived by removing water at the higher rate, or the slope of the cost curve equals

the slope of the benefit curve. As shown in figure 7A-10 and table 7A-13, moving from the 0.3-inch to the 0.4-inch rate, benefits increase \$6,611 whereas costs increase only \$2,536. In moving from the 0.4-inch to the 0.5-inch rate, benefits increase \$2,413 whereas costs increase \$1,113. However, in moving from the 0.5-inch to the 0.6-inch rate, benefits increase only \$349 whereas costs increase \$5,036. Then somewhere between the 0.5-inch and 0.6-inch rate is the appropriate pumping rate to use. Considering the accuracy of topographic coverage and the cost spread between increments, the 0.5-inch is selected.

Table 7A-13, Relationships - cost-benefit at various pumping rates

Pumping Rate	Change in Benefits	Change in Costs
0.3	-	-
0.4	6,611	2,536
0.5	2,413	1,113
0.6	349	5,036

APPENDIX B

Design of Farm Drainage Pumping PlantExample

A pumping plant is required to remove runoff from 236 acres of low land on a 440-acre farm near Bayou John, Louisiana in order to grow sugarcane. Drainage of higher land on the farm has been diverted from the low area to an adequate gravity outlet. The low land is protected from tidal overflow by a border dike constructed from materials excavated from adjoining ditches within the protected area. The land lacks sufficient elevation for adequate gravity drainage into the tidal outlet. Surveys show ground elevation in low areas at -1.0 mean sea level and near the proposed pump site at -1.5 msl. Elevation in bottom of ditch at the pump site is -5.5 msl. Average yearly high tide is El. 2.0 msl and a 10-year frequency high water is El. 3.0 msl. Soils are poorly drained Sharkey clay loam which permit little seepage into the area and provide no appreciable ground water storage or field ditch storage for runoff in the required surface drainage system. Some storage is available in the borrow ditches along the dikes. A gasoline engine will be used to supply power to the pump to be housed over a concrete sump. Pump discharge will be piped over the dike.

Pump plant location

The pumping plant will be located within several hundred feet of Point A as shown in general layout figure 7B-1 and between the dike and borrow ditch.

Pump plant capacity

The pump capacity will be the required runoff removal rate for the 236 acres at 3 inches in 24 hours as determined from the local drainage guide, less the storage available in the borrow ditches which is equal to 0.43 inch, or a net rate of 2.57 inches in 24 hours.

$$\begin{aligned} \text{Pump capacity} &= \frac{\begin{array}{cccc} \text{(ac.)} & & \text{(sq.ft./ac.)} & & \text{(in./day)} & & \text{(gal./cu.ft.)} \\ 236 & \times & 43,560 & \times & 2.57 & \times & 7.48 \end{array}}{\begin{array}{cccc} 12 & & 24 & & 60 \\ \text{(in./ft)} & & \text{(hrs./day)} & & \text{(min./hr.)} \end{array}} \\ &= 11,436 \text{ GPM} \end{aligned}$$

Pump type and size

Stage in the sump will fluctuate between -5.5 feet and -1.5 feet with an average stage of -3.5 feet. Minimum static head will be 4.5 feet (-1.5' msl to +3.0' msl). Maximum static head will occur when the sump is empty, equal to 8.5 feet (-5.5' msl to +3.0' msl), and is expected to be of short duration. (See figure 7B-2.) Pump selection, therefore, may be based on average static head, but the power supply on maximum static head to avoid possible engine overload when pumping at the maximum head.

Based on little seepage, moderate capacity, and low risk damage in case of temporary pump failure, only one pump will be used. Based on low pumping head and moderate capacity (also see selection chart figure 7-4) and

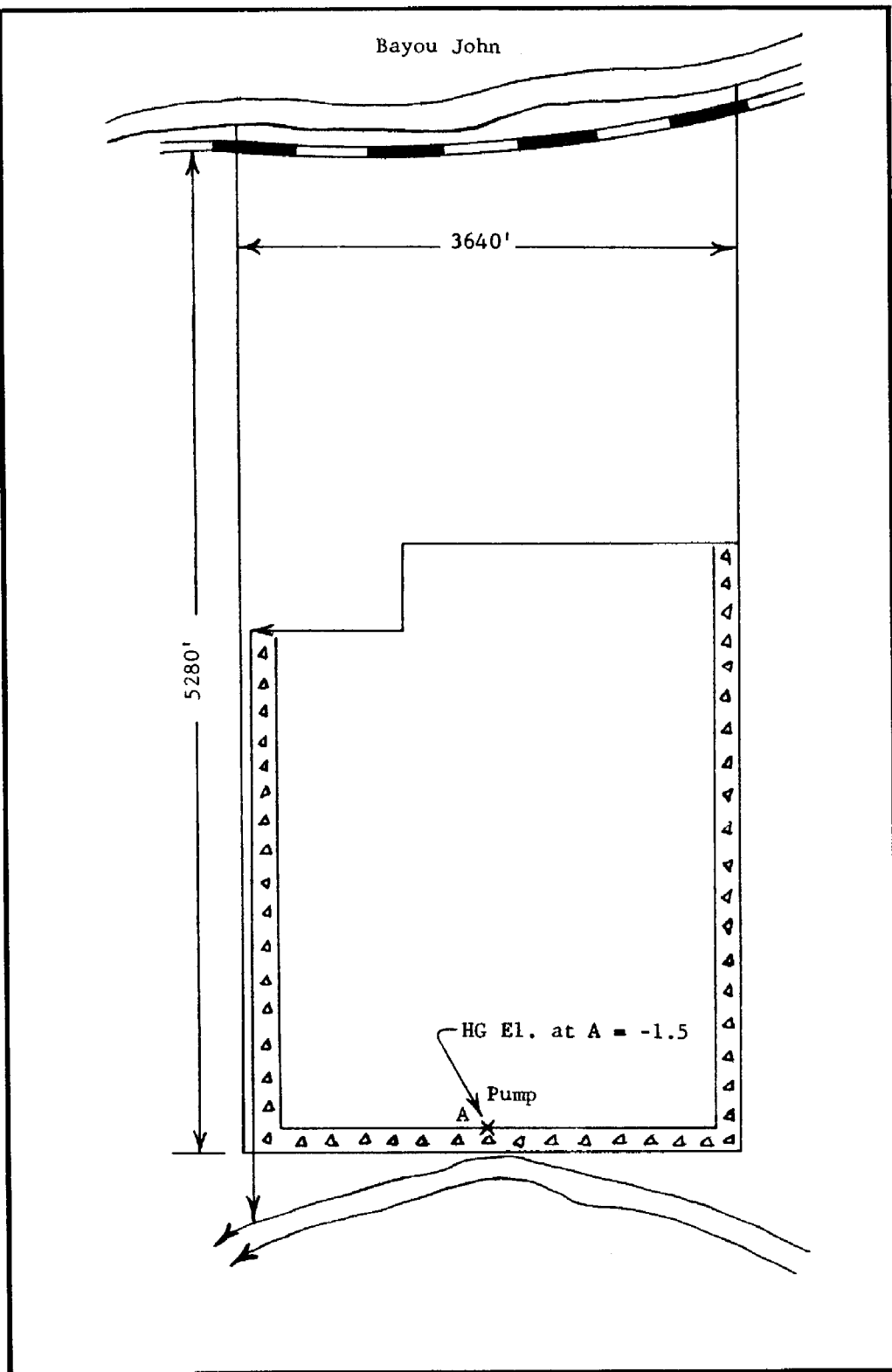

Figure 7B-1, Pump drainage site layout

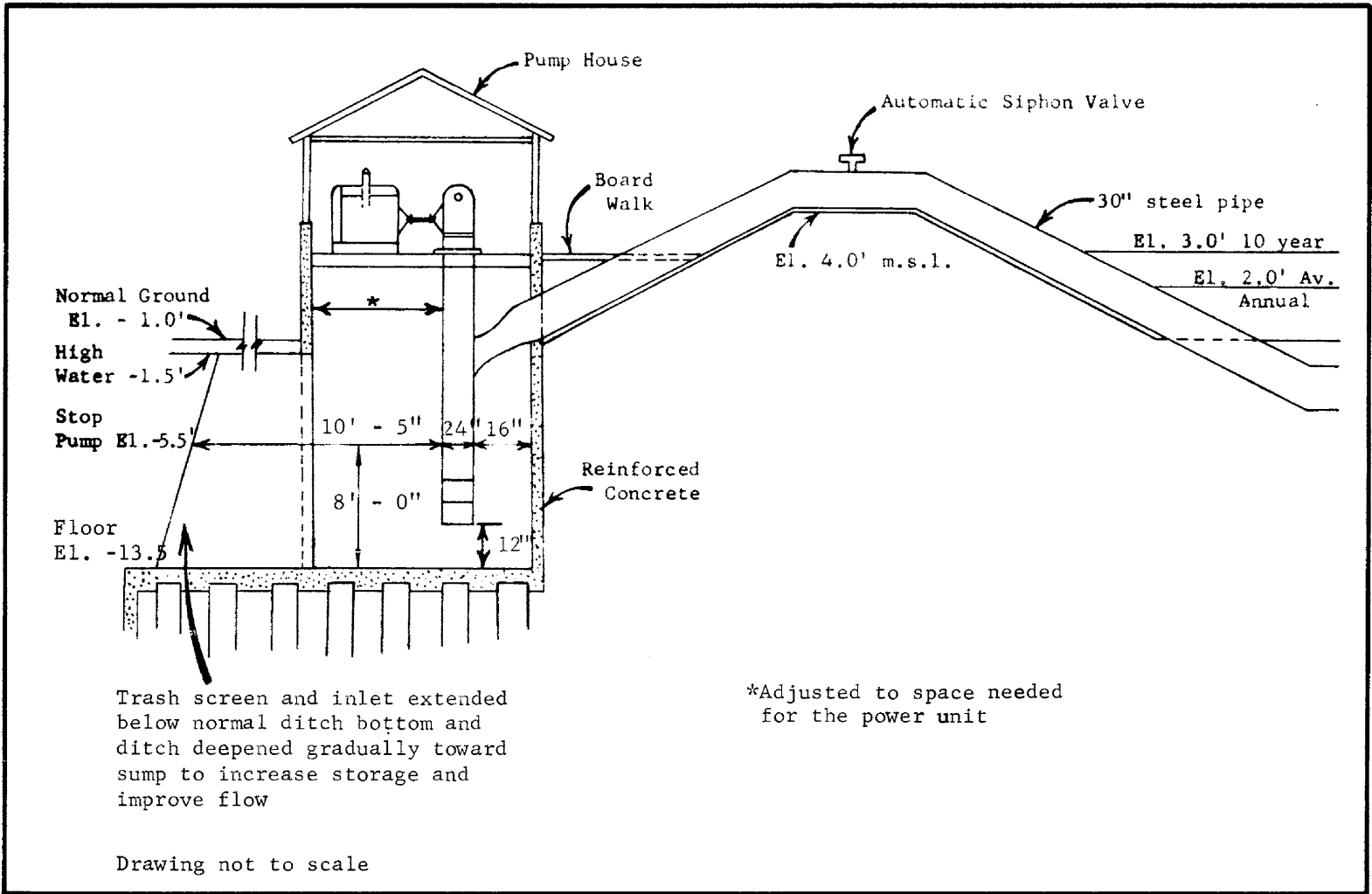

Figure 7B-2, Cross section of pumping plant layout

manufacturer's pump recommendations (figures 7B-3 and 7B-4), a propeller pump will be used. A 10 feet per second discharge velocity is used as in the range of efficient pump performance for a capacity of 11,436 GPM (equal to 25.5 cfs).

The required pump cross section area $A = \frac{Q}{V} = \frac{25.5}{10} = 2.55$ square feet

The required pump diameter = $\left(\frac{4A}{\pi}\right)^{1/2} = \left(\frac{4 \times 2.55}{3.1416}\right)^{1/2}$
 = 1.8 ft. = 21.6 in. or say 22 in.
 (also see table 7-4)

A 24-inch diameter pump will be used as nearest manufactured size readily available.

Engine size

A gasoline engine with drive through gearbox will be used.

24-inch pump velocity (V_1) at design discharge = $\frac{Q}{A} = \frac{25.5}{3.1416} = 8.12$ fps

Velocity head (h_{V_1}) = $\frac{V_1^2}{2g} = \frac{65.93}{64.4} = 1.02$ (also see figure 7-6)

Discharge pipe is to be enlarged from 24-inch diameter (d_1) at pump to 30-inch diameter (d_2) within distance of 2 feet. Loss in head (h_2) from gradual enlargement may be computed from formula 6-33 and values in table 6-8 of King and Brater Handbook of Hydraulics (9).

$$h_2 = K_2 \left(\frac{V_1^2}{2g}\right) = 0.09 \times 1.02 = 0.09 \text{ feet}$$

where:

V_1 = velocity in smaller pipe = 8.12

K_2 = value from table = 0.09 for $\frac{d_2}{d_1} = \frac{30}{24} = 1.25$ and

angle of cone = $14^\circ 20'$ (approx.)

$\tan 1/2$ angle = $\frac{0.25}{2.0} = 0.125$ -- $1/2$ angle = $7^\circ 10'$ (approx.)

Velocity at discharge (V_2) = $\frac{25.5}{4.9} = 5.2$ fps where cross section area
 of 30-inch steel pipe = 4.9 square feet

Velocity head (h_{V_2}) = $\frac{V_2^2}{2g} = \frac{27.0}{64.4} = 0.42$ foot

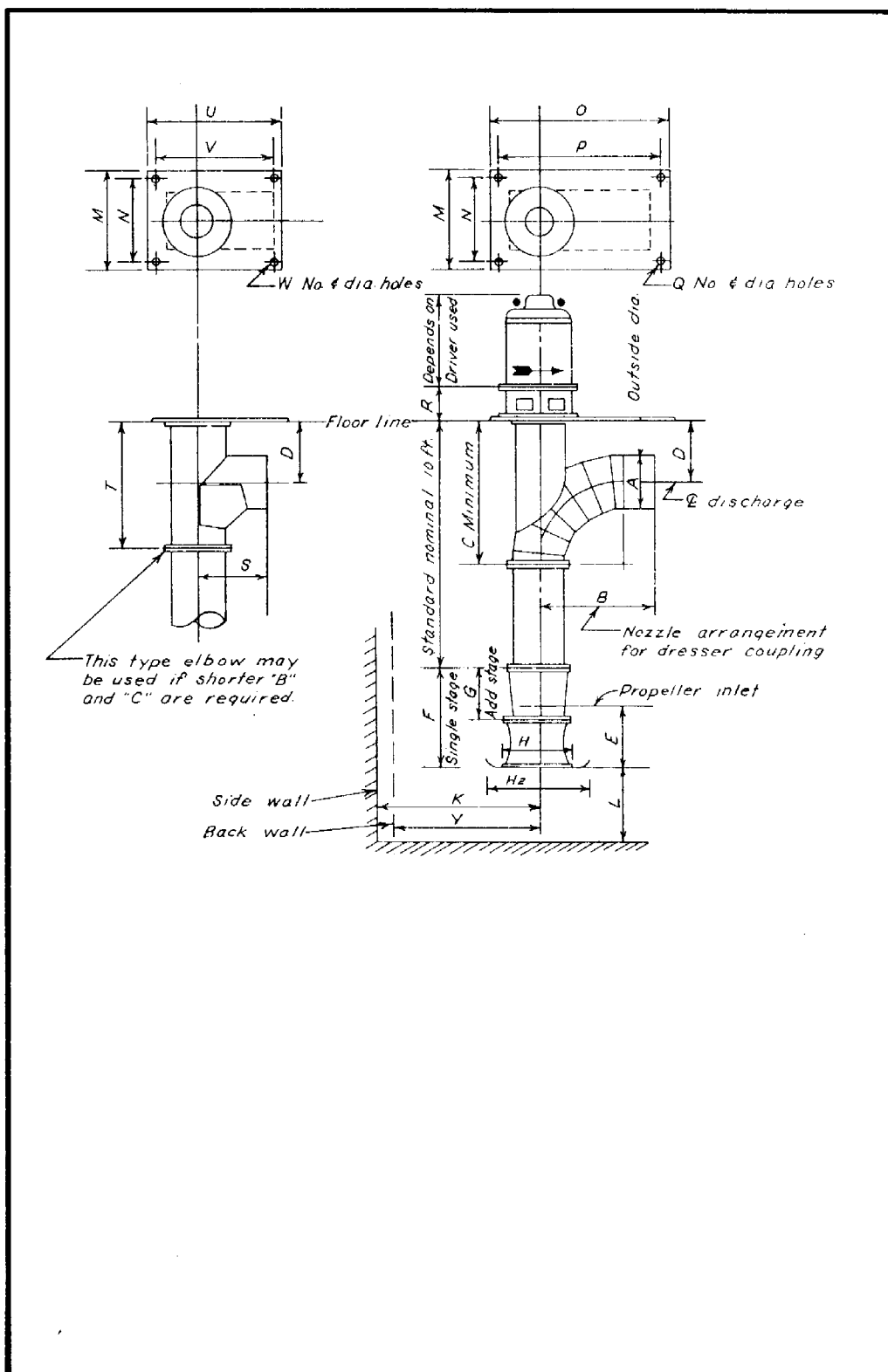

Figure 7B-3, Layout of principal dimensions - vertical axial flow pumps

PRINCIPAL DIMENSIONS IN INCHES (UNLESS OTHERWISE NOTED)

SIZE OF PUMP	A COL	B	C	D	E	F	G	H		⁺ K	L	M	N	O	P	Q	R	S	T	U	V	W	H ₂	Y
8	8	18	2'-6"	18	6 1/4	13	8	12 3/4		15	5	20	16	2'-6"	2'-2"	4 (7/8)	8	14	2'-2"	2'-2"	22	4 (7/8)	24	11
10	10	21	2'-9"	18	8 1/4	16 1/4	9 1/4	15 1/2		18	6	24	20	2'-10"	2'-6"	4 (7/8)	8	15	2'-3"	2'-4"	24	4 (7/8)	30	13
12	12	24	3'-0"	18	9 3/4	19	10 3/4	18		21	7	2'-2"	22	3'-2"	2'-10"	4 (1)	8	17	2'-5"	2'-7"	2'-3"	4 (1)	35	14
14	14	2'-5"	3'-9"	24	10	21	12 1/2	21		24	8	2'-6"	2'-2"	3'-6"	3'-2"	4 (1)	8	18	3'-0"	2'-9"	2'-5"	4 (1)	42	1'-3"
16	16	2'-6"	4'-0"	24	12	2'-0 1/4	14 1/4	25		2'-6"	9	3'-0"	2'-6"	4'-0"	3'-6"	4 (1)	8	20	3'-2"	3'-2"	2'-8"	4 (1)	46	1'-5"
18	18	2'-11"	4'-3"	24	12	2-3 1/4	15	28		2'-9"	10	3'-2"	2'-8"	4'-6"	4'-0"	4 (1 1/8)	8	22	3'-4"	3'-5"	2'-11"	4 (1)	48	1'-7"
20	20	3'-2"	4'-6"	24	13 1/2	2-6 1/2	16 1/2	32		3'-0"	11	3'-6"	3'-0"	4'-10"	4'-4"	4 (1 1/8)	8	24	3'-6"	3'-8"	3'-2"	4 (1)	54	1'-9"
24	24	3'-8"	5'-6"	2'-6"	19	3'-2"	19 1/2	36		3'-6"	12	3'-10"	3'-4"	5'-6"	5'-0"	4 (1 1/4)	8	2'-3"	4'-3"	4'-11"	3'-7"	4 (1 1/8)	60	1'-11"
30	30	4'-5"	6'-3"	2'-6"	21 1/2	4'-0"	2'-1"	42		4'-0"	15	4'-4"	3'-10"	6'-6"	6'-0"	6 (1 1/4)	8	2'-8"	4'-8"	4'-9"	4'-3"	4 (1 1/8)	72	2'-0"
36	36	5'-2"	7'-6"	3'-0"	23	4'-6"	—	54		5'-0"	18	5'-4"	4'-10"	7'-6"	7'-0"	6 (1 1/4)	8	3'-0"	5'-6"	5'-4"	4'-10"	4 (1 1/4)	84	2'-6"
42	42	5'-11"	8'-3"	3'-0"	2-3 1/2	5'-11"	—	64		6'-0"	22	6'-3"	5'-9"	8'-6"	8'-0"	8 (1 1/4)	12	3'-4"	5'-10"	6'-3"	5'-9"	8 (1 1/4)	96	3'-0"
48	48	6'-8"	9'-0"	3'-0"	2-7 1/2	5'-11"	—	74 1/2		7'-0"	25	7'-2"	6'-8"	9'-6"	9'-0"	8 (1 1/4)	12	3'-10"	6'-2"	7'-2"	6'-8"	8 (1 1/4)	112	4'-3"
54	54	6'-3"	9'-1 1/2	3'-6"	2'-11"	6'-8 1/2	—	85 1/2		8'-0"	29	8'-2"	7'-8"	9'-6"	9'-0"	8 (1 1/4)	12	4'-4"	7'-2"	8'-2"	7'-8"	8 (1 1/4)	128	4'-6"
60	60	6'-9"	10'-3"	4'-0"	3'-3"	7'-7 1/2	—	96		9'-0"	33	9'-0"	8'-6"	10'-5"	9'-9"	8 (1 1/2)	12	4'-10"	8'-2"	9'-0"	8'-6"	8 (1 1/2)	144	4'-9"
72	72	6'-6"	10'-6"	4'-6"	3'-4"	8'-3"	—	115		10'-9"	39	10'-6"	10'-0"	10'-6"	10'-0"	16 (1 1/2)	18	—	—	—	—	—	172	5'-0"
84	84	7'-6"	12'-0"	5'-0"	3'-10"	9'-8"	—	134		12'-6"	45	12'-4"	11'-10"	12'-4"	11'-10"	16 (1 1/2)	18	—	—	—	—	—	201	6'-0"
96	96	8'-6"	13'-6"	5'-6"	4'-4"	11'-0"	—	154		14'-0"	51	13'-10"	13'-4"	13'-10"	13'-4"	16 (1 1/2)	18	—	—	—	—	—	231	6'-6"
120	120	10'-6"	16'-6"	6'-6"	4'-9"	13'-6"	—	189		16'-0"	63	16'-9"	16'-3"	16'-9"	16'-3"	16 (1 1/2)	24	—	—	—	—	—	283	8'-4"
144	144	12'-6"	19'-6"	7'-6"	5'-9"	16'-9"	—	234		20'-0"	75	20'-6"	20'-0"	20'-6"	20'-0"	16 (1 1/2)	24	—	—	—	—	—	351	10'-3"

*Split base plate.

⁺"K"=distance from pump vertical center line to side wall.

"2K"=distance between the vertical center lines of 2 pumps without separating wall.

"Y"=distance from pump vertical center line to back wall but should be increased to H₂/2 when increased bell diameter (umbrella) is used.

Figure 7B-4, Table of principal dimensions - vertical axial flow pumps

Friction loss in 44 feet of 30-inch steel pipe over the dike using Manning equation, formula 6-26c King and Brater Handbook of Hydraulics (9) (also see figure 7-6) equals

$$h_f = \frac{2.87 n^2 \ell V_2^2}{d^{4/3}} = \frac{2.87 \times (0.015)^2 \times 44 \times (5.2)^2}{(2.5)^{4/3}} = 0.23 \text{ ft.}$$

where:

h_f = head loss in feet

n = friction factor = 0.015

ℓ = length of pipe in feet = 44

V_2 = velocity in discharge pipe in fps = 5.2

d = diameter of pipe in feet = 2.5

Friction loss in bends (for long radii up to 45°) using formula 6-39 and figure 6-5 for 90° bends, and 25 percent reduction for 45° bends, from King and Brater Handbook of Hydraulics (9), loss in one 45° bend equals

$$\begin{aligned} h_b &= 0.75 K_b \left(\frac{V^2}{2g} \right) \\ &= 0.75 \times 0.20 \times 0.42 \\ &= 0.063 \text{ ft.} \end{aligned}$$

where the value of K_b in figure 6-5 for a bend radius (R) to pipe diameter (d) of $\frac{12.5}{2.5}$ or 5 is equal to 0.2.

Total h_d for 3 bends = $3 \times 0.063 = 0.19$ ft.

Total significant losses plus velocity head at discharge

$$\begin{aligned} &= h_2 + h_f + h_b + h_{V_2} \\ &= 0.09 + 0.23 + 0.19 + 0.42 = 0.93 \text{ ft.} \end{aligned}$$

Total head equals static head plus significant head losses plus velocity head

$$= 8.50 + 0.93 = 9.43 \text{ ft.}$$

Required power

Pending final selection of engine and pump, the following efficiencies are assumed in order to determine approximate engine size required: pump 70%, transmission 95%, and engine 70%.

Then required horsepower is

$$\begin{aligned} \text{BHP} &= \frac{\text{GPM} \times \text{Total Head}}{3,960 \times \text{Efficiency}} \\ &= \frac{11,436 \times 9.43}{3,960 \times 0.70 \times 0.95 \times 0.70} \\ &= \frac{107,841}{1,843} = 58.5 \end{aligned}$$

Use 60 horsepower engine.

Assuming the design specific speed of the pump in the required range of head and capacity of 17,500 (see figures 7-8 and 7-11 and the Hydraulic Institute Standards (1)), RPM of the pump at design capacity can be computed from equation 7-5 where

$$\begin{aligned} \text{RPM} &= \frac{\text{Specific Speed} \times (H)^{3/4}}{(\text{GPM})^{1/2}} \\ &= \frac{17,500 \times (9.43)^{3/4}}{(11,436)^{1/2}} = \frac{17,500 \times 5.4}{107} \\ &= 885 \end{aligned}$$

Using a standard heavy duty gasoline engine of an operating speed of 1,800 RPM, a 2 to 1 reduction gear transmission is required.

Sump dimensions

Using Hydraulic Institute recommendations (see figures 7-14 and 7-15) pending final design adjustments to meet manufacturer's requirements (see figures 7B-3 and 7B-4) of the selected pump, the following sump dimensions should be provided:

Bottom of pump bell to top of sump floor	12 inches
Centerline of pump to backwall of sump	28 inches
Centerline of pump to sidewall of sump	32 inches
Sump floor below pump-stop level (El. -5.5)	96 inches
Center of trash rack to back wall of sump	165 inches

Other dimensional requirements in determining final sump size (not covered herein) will include space necessary for housing the selected pump, power and transmission unit, weight against buoyant uplift, and flow entrance to limit velocity and provide capacity.

